



# **ORIGINAL OPERATING INSTRUCTIONS**

## **S-Line Dust Extractor**

**S13**

**S26**

**S36**

**READ ALL INSTRUCTIONS BEFORE USE**

# Introduction

Dear Customer,

Thank you for choosing Pullman Ermator as your supplier.

We hope that the S-Line dust extractor will be to your satisfaction and meet your expectations.

Pullman Ermator have manufactured professional dust extractors since 1966 and has over the years acquired a genuine technical knowledge in this area. We are continuously striving to improve our products in our product segment and will continue to supply the market with new equipment.

## Notice!

**These instructions are only for S-Line Dust Extractors.**

**The S-Line Dust Extractors are designed to clean construction areas and be connected to small electrical machines such as drills, grinders etc. The machine is suitable for picking up dry, non-flammable dust and debris in and indoor environment. It is not suitable for picking up liquids.**

**Pullman Ermator will not be held responsible if the dust extractor is used for other applications or been used in ways other than those outlined in this instruction manual.**

**Please pay particular attention to the safety regulations.**

**Read the complete instruction manual before using your dust extractor.**

**All spare parts used with the dust extractors must be those specified by Pullman Ermator.**

## Table of contents

<b>1</b>	<b>SAFETY INSTRUCTIONS</b>	<b>8</b>	<b>WARRANTY</b>
<b>2</b>	<b>UNPACKING</b>	<b>9</b>	<b>PROBLEM SOLVING</b>
<b>3</b>	<b>FUNCTION</b>	<b>10</b>	<b>TECHNICAL DATA</b>
<b>4</b>	<b>FILTER CLEANING</b>	<b>11</b>	<b>PLUGS</b>
<b>5</b>	<b>DUST STORAGE SYSTEM</b>	<b>12</b>	<b>DECLARATION OF CONFORMITY</b>
<b>6</b>	<b>FILTER CHANGE</b>	<b>13</b>	<b>EXPLODED VIEWS</b>
<b>7</b>	<b>SERVICE</b>	<b>14</b>	<b>NOTES</b>

# 1. SAFETY INSTRUCTIONS

When using an electrical appliance, basic precautions should always be followed, including the following:

## **WARNING – To reduce the risk of fire, electric shock or injury:**

- Cables damaged through crushing or splitting can be dangerous if used and should be replaced immediately. Risk of personal injury.
- Make sure the assembly area is firm, so the dust extractor does not tip over. Risk of personal and material injury.
- Risk of pinching when handling the toggle fasteners.
- The machine must not be used in environments where explosive gases may be present. Serious risk of explosion.
- Improper connection of the equipment-grounding conductor can result in a risk of electrical shock. Check with a qualified electrician or service person if you are in doubt as to whether the outlet is properly grounded. Do not modify the plug provided with the machine. If it will not fit the outlet. Have a proper outlet installed by a qualified electrician.
- Before using the machine, make sure that the power & voltage corresponds with the voltage shown on the machines rating plate.
- Do not leave machine when plugged in. Unplug cord from outlet when not in use and before cleaning or servicing machine.
- Do not use outdoors or on wet surface, this machine is for indoor and dry use only.
- Do not allow to use as a toy. Close attention is necessary when used by or near children.
- Use only as described in this manual. Use only manufacturers recommended attachments.
- Operators shall be adequately instructed on the use of the machine
- This machine is not intended for use by persons (including children) with reduced physical, sensory or mental capabilities, or lack of experience and knowledge.
- Do not use with damaged cord or plug. If the machine is not working as it should, has been dropped, damaged, left outdoors or dropped in water. Make sure it is repaired by a qualified person.
- Do not pull or carry by cord, use cord as handle, close a door on cord, or pull cord around sharp edges or corners. Do not run the machine over cord. Keep cord away from heated surfaces.
- Do not unplug by pulling on cord. To unplug, grasp the plug. Not the cord.
- Do not handle plug or machine with wet hands.
- Regularly inspect cord and plug for damage. If cord is damaged, it must be replaced by a qualified person in order to avoid hazard.
- Do not put any object into openings. Do not use with any opening blocked (accept during filter cleaning procedure). Keep free of dust, hair and anything that may reduce airflow.
- Keep hair, loose clothing, fingers and all parts of body away from openings and moving parts.
- Turn off all controls before unplugging.
- Do not use to pick up flammable or combustible liquids, such as gasoline, or use in areas where they may be present.
- Do not pick up any type of liquids.
- Do not pick up anything that is burning or smoking, such as cigarettes, matches or hot ashes.
- Use extra care when cleaning on stairs.
- Do not use without dust bag and/or filters in place. Replace collection system and/or filters as described in manual.
- If using an extension cord make sure the cord rating is suitable for this machine.
- Do not modify machine from its original design.
- Keep children and unauthorized persons away from machine when in use.
- All repairs must be performed by a qualified service person. Use only manufacturer-supplied or equivalent replacement parts.
- Do not expose machine to rain or moisture. Store indoors only.
- Connect to a properly grounded outlet only. See grounding instructions.

## THERMAL PROTECTION

- The dust extractor is equipped with a safety thermal protector to prevent motor from overheating. Should thermal protector activate, turn off machine, unplug power cord and check for full dust bag, vacuum hose clog or filter blockage. It may take up to 45 minutes for the thermal protector to reset.

## GROUNDING INSTRUCTION

- The dust extractor must be grounded. If it should malfunction or breakdown, grounding provides a path of least resistance for electric current to reduce the risk of electric shock. The dust extractor is equipped with a cord having an equipment-grounding conductor and grounding plug. The plug must be inserted into an appropriate outlet that is properly installed and grounded in accordance with all local codes and ordinances.

## SAFETY LABEL

- The following label appears on the machine, next to the machines rating plate. Replace label if it is missing, becomes damaged or illegible. Failure to follow this warning label may result in fire, electric shock or injury.

**WARNING:**  
\*To reduce the risk of electric shock. Do not use outdoors or on wet surfaces.  
\*To reduce the risk of electric shock, unplug before cleaning or servicing.

**AVERTISSEMENT:**  
\*Pour réduire les risques de choc électrique, ne pas utiliser à l'extérieur et ne pas aspirer de matières humides.  
\*Pour éviter les risques de choc électrique, débrancher avant le nettoyage ou l'entretien.

## 2. UNPACKING

When unpacking the machine, please check that the following accessories are included:

- The hose with end fittings.
- Wand.
- Floor nozzle.

If any of the above-mentioned parts are missing, please contact your local distributor or our sales representative. For models that do not already have the front casters assembled due to packaging limitations. Assemble the front casters using the using bolt or nut and washer that are included in the package depending on your application.

Protect the environment:

Please dispose of packaging materials and used machine components in an environmentally safe way according to local disposal regulations. Always remember to recycle.

## 3. FUNCTION

**The machine is designed for vacuuming and separating dry, non-combustible dust with an explosion limit value of  $>0.1\text{mg/m}^3$ .**

The dust extractor is started by the switch.

Type	Models without automatic start	Autostart function models
Red switch 2 step	0: Motor off, 1: Motor on	N/A
Black switch 3 step	N/A	0: Motor off, 1: Motor on, 2: Automatic start

Dust-laden air is then sucked through the inlet valve at high speed via the suction hose. The air is slowed down by the cyclone and coarse dust particles are separated out, partly by centrifugal force and partly by gravity. Air and finer particles then pass through the double filter system where separation is made. The machine is designed for filter cleaning by reverse air pulse.

The separated dust accumulates in the cyclone until the machine is switched off, when it drops through the bottom flap into the plastic bag. The filter cleaning process is not completed before it is clear that the dust inside the tank has fallen down into the collection bag. In some extreme cases the adhesive ability of the dust must be broken manually. This can be done by hitting the dust through the bag or tapping the tank using i.e. a rubber hammer.

**Automatic start function:** When you use the dust extractor together with another machine, there is an electrical outlet on the dust extractor. Connect the machine to this outlet. Then when you start it up the dust extractor will also start after approx. 1-2 seconds. When you turn it off, the dust extractor will continue to run for approximately 10 seconds. To empty the hose. Then stop

## 4. FILTER CLEANING

The filter must be cleaned from time to time. This must be done before changing the bag collection system and should also be done when work is completed or when there is poor suction.

**Procedure:** Cover the inlet, if applicable, use attached cover. First let the machine build up vacuum for four to five seconds then quickly push down on the key and release it. Repeat the procedure five times. It is important to let the machine rebuild the vacuum in between every repetition.

**Turn off the motor and wait until it stops completely, then uncover the inlet.**

If suction remains poor, the pre-filter needs to be replaced. If suction still remains poor afterwards, the Hepa filters needs to be replaced. See instructions in chapter 6. FILTER CHANGE.

## 5. DUST STORAGE SYSTEM

The dust extractors are mainly equipped with Longopac system for effective dust storage or a regular plastic bag system depending on model. Longopac is a 22 m long plastic tube that will be divided into plastic bags using the zip ties attached with the machine.

**To assemble a new Longopac bag:** Release the belt holding the last bag. Remove the holder, put in a new Longopac bag & pull out the inner end upwards. Assemble the holder on to the machine and strap the opening facing upwards with the belt. Pull down the outside end and close it using a zip tie.

All dust extractors can be used with original Pullman Ermator dust bags for single use. Also all models can be fitted with the longopac system.

Only change Longopac or regular bag after filter cleaning cycle have been completed.

## 6. FILTER CHANGE

**Risk of dust dispersion - Use personal safety equipment**

**Unhealthy dust can be spread during filter change. Accordingly, the user should wear protective glasses, protective gloves, and a breathing mask conforming to protection class FFP3.**



wear breathing mask

wear ear protection

wear protective glasses

### WARNING

**Remember to switch off the machine and pull the plug out of the outlet before servicing.**

### Pre-filter

Loosen the 3 clamps and remove the top. Take the bag from the new filter.

Lift out the filter and place it gently in a plastic bag. This bag must be properly disposed.

Insert a new filter.

### Important:

If you are removing the Pre-filter in order to clean it. Hitting the filter with force or use of compressed air will destroy the filter. It can handle water, but high pressure water cleaning will destroy it.

### Hepa Filter

Loosen the two nuts on each filter cover cap. Carefully lift the filter into a clean plastic bag, use the bag from the new filter. This bag must be properly disposed. Insert a new filter in reverse order.

### Important:

Hepa filters can't be cleaned, trying this might destroy it. When installing the replacement filter, make sure to not touch the inside of the filter. Any kind of force/damage on the inside of filter media will destroy the new filter.

## 7. SERVICE

- When cleaning and servicing the machine, you must switch off the machine and remove the plug from the outlet.
- Avoid cleaning with a high pressure cleaner. If necessary, do not direct at the openings on the machine, especially the opening for cooling air.
- Before moving the machine from the work area, the machine must be cleaned.
- All other equipment must be regarded as contaminated and be treated thereafter.
- If possible, use a special suitable room.
- Proper personnel protective equipment must be used. Dust can be spread when the coarse filter and the absolute filter are replaced that can be hazardous to health. Accordingly, the user should wear protective glasses, protective gloves, and a breathing mask conforming to protection class FFP3.
- All parts which are contaminated after service must be properly disposed of in plastic bags according to all regulations.
- If the machine has to be used for other purposes, it is extremely important that the machine is cleaned, to avoid the spread of hazardous dust.
- Do not puncture the Hepa filter. Risk of dust dispersion.

### Replacement parts, Filters and Dust collection system

Part no:	Description	S13	S26	S36
1376013	Longopac (4-bags)	1	1	1
1276008	Plastic bags (25-pcs)	1	1	1
201000016	Pre-filter S13	1	N/A	N/A
201000016a	PTFE Pre-filter S13	1	N/A	N/A
200900050	Pre-filter S26	N/A	1	N/A
200900050a	PTFE Pre-filter S26	N/A	1	N/A
200900051	Pre-filter S36	N/A	N/A	1
200900051a	PTFE Pre-filter S136	N/A	N/A	1
200700070	HEPA FILTER S-LINE	1	2	3
200700070a	HEPA FILTER S-LINE USA	1	2	3

## 8. WARRANTY

All Pullman Ermator devices and accessories have a 12-month factory warranty for material and manufacturing defects. The warranty extends to 36 months when returning the attached warranty slip. Do not attempt to repair the suction apparatus without the consent of the manufacturer.

The warranty does not cover defects which are the result of normal wear and tear, negligence, defective use, unauthorised repair or the suction apparatus being connected to the incorrect voltage.

In the event of any complaint, the suction apparatus or an agreed part of it must be returned to us or our authorised representative for warranty examination and for any warranty repair or replacement.

## 9. PROBLEM SOLVING

The dust extractors are designed and manufactured for severe environments and tasks, but the user must note that the machine must be protected from knocks and blows. Filter, seals, attachments, and connections are carefully adapted and selected with regard to the operator's work environment. Therefore, the operator and service personnel must treat the machine with care in order for it to work correctly for many years.

<b>Issue</b>	<b>Cause</b>	<b>Solution</b>
Motor doesn't start	No power	Plug in machine
	Cable defective	Replace cable
	Switch defective	Replace switch
	Soft start defective	Replace soft start
Motor stops immediately after starting	Wrong fuse	Connect to correct fuse
	Shortcut in cable/machine	Order service
Motor runs but there is not suction	Hose not connected	Connect hose
	Hose clogged/blocked	Clean hose
	No dust collection bag	Fit dust collection system
Motor runs but poor suction	Hole in hose	Replace hose
	Filter clogged	Clean filter/Replace filter
	Loose top cover	Adjust
	Defective gaskets	Replace affected gaskets
Dust blown from motor	Wrongly assembled or damaged filter system	Adjust/Replace filters
Abnormal noise		Order service

**SAVE THESE INSTRUCTIONS!**

## 10. TECHNICAL DATA

Data	Unit	S13 120 V	S13 230 V	S26 120 V	S26 230 V	S36 230 V	S36 120 V
Voltage (single phase)	V	120	230	120	230	230	120
Power (max)	W	1200	1200	2400	2400	3600	2400
	HP	1,6	1,6	3,2	3,2	4,8	3,2
Current (UL)	A	8	4	16	8	12	16
airflow (max)	m3/h	200	200	400	400	600	485
	cfm	118	118	236	236	354	285
Vacuum (max)	kPa	24	22	24	22	22	18
	Inch "	100	90	100	90	90	72
Main hose	Metric (mm)	4m x 38	4m x 38	7,5m x 51	7,5m x 51	10m x 63	10m x 63
	USCS	13' x 1,5"	13' x 1,5"	24' x 2"	24' x 2"	32' x 2,5"	32' x 2,5"
Inlet	Metric (mm)	51	51	63	63	63	63
	USCS	2"	2"	2,5"	2,5"	2,5"	2,5"
Pre-filter EN779-F8	% @ 1um	>99,5	>99,5	>99,5	>99,5	>99,5	>99,5
Pre-filter area	metric	1,5 m <sup>2</sup>	1,5 m <sup>2</sup>	3 m <sup>2</sup>	3 m <sup>2</sup>	4,5 m <sup>2</sup>	4,5 m <sup>2</sup>
	USCS	16 ft <sup>2</sup>	16 ft <sup>2</sup>	32 ft <sup>2</sup>	32 ft <sup>2</sup>	48 ft <sup>2</sup>	48 ft <sup>2</sup>
Hepa filter EN1822-H13	% @ 0,3um	>99,99	>99,99	>99,99	>99,99	>99,99	>99,99
total hepa filter area	metric	1,2 m <sup>2</sup>	1,2 m <sup>2</sup>	2,4 m <sup>2</sup>	2,4 m <sup>2</sup>	3,6 m <sup>2</sup>	3,6 m <sup>2</sup>
	USCS	13 ft <sup>2</sup>	13 ft <sup>2</sup>	26 ft <sup>2</sup>	26 ft <sup>2</sup>	39 ft <sup>2</sup>	39 ft <sup>2</sup>
Sound level	dB(a)	70	70	70	70	70	70
Dust collection system	type	Plastic bag	Plastic bag	Longopac	Longopac	Longopac	Longopac
Dimensions (L*W*H)	metric (mm)	680x400x1100	680x400x1100	756x546x1275	756x546x1275	840x620x1500	840x620x1500
	USCS	26x15,8x43,3 "	26x15,8x43,3 "	29x21,5x50,2 "	29x21,5x50,2 "	33x24,5x60 "	33x24,5x60 "
Weight	metric	29 kg	29 kg	47 kg	47 kg	63 kg	63 kg
	USCS	66 lbs	66 lbs	105 lbs	105 lbs	140 lbs	140 lbs



# 11. PLUGS

MODEL	PLUG TYPE	RECEPTACLE TYPE	RECEPTACLE MAX AMPS	CABLE & PLUG MAX AMPS
S13 120 V	NEMA 5-15	N/A	N/A	15 A
S13 230 V	SOCKET F GROUNDED	SOCKET F	5 A	10 A
S26 120 V	NEMA 5-20	N/A	N/A	20 A
S26 230 V US	NEMA L6-15	N/A	N/A	15 A
S26 230 V	SOCKET F GROUNDED	N/A	N/A	10 A
S36 120 V US	NEMA 5-20	N/A	N/A	20 A
S36 230 V 30A	NEMA L6-30	NEMA L6-30	20 A	30 A
S36 230 V 50A	NEMA L6-50	NEMA L6-50	35 A	50 A
S36 230 V	IEC 60309 16 A	N/A	N/A	16 A

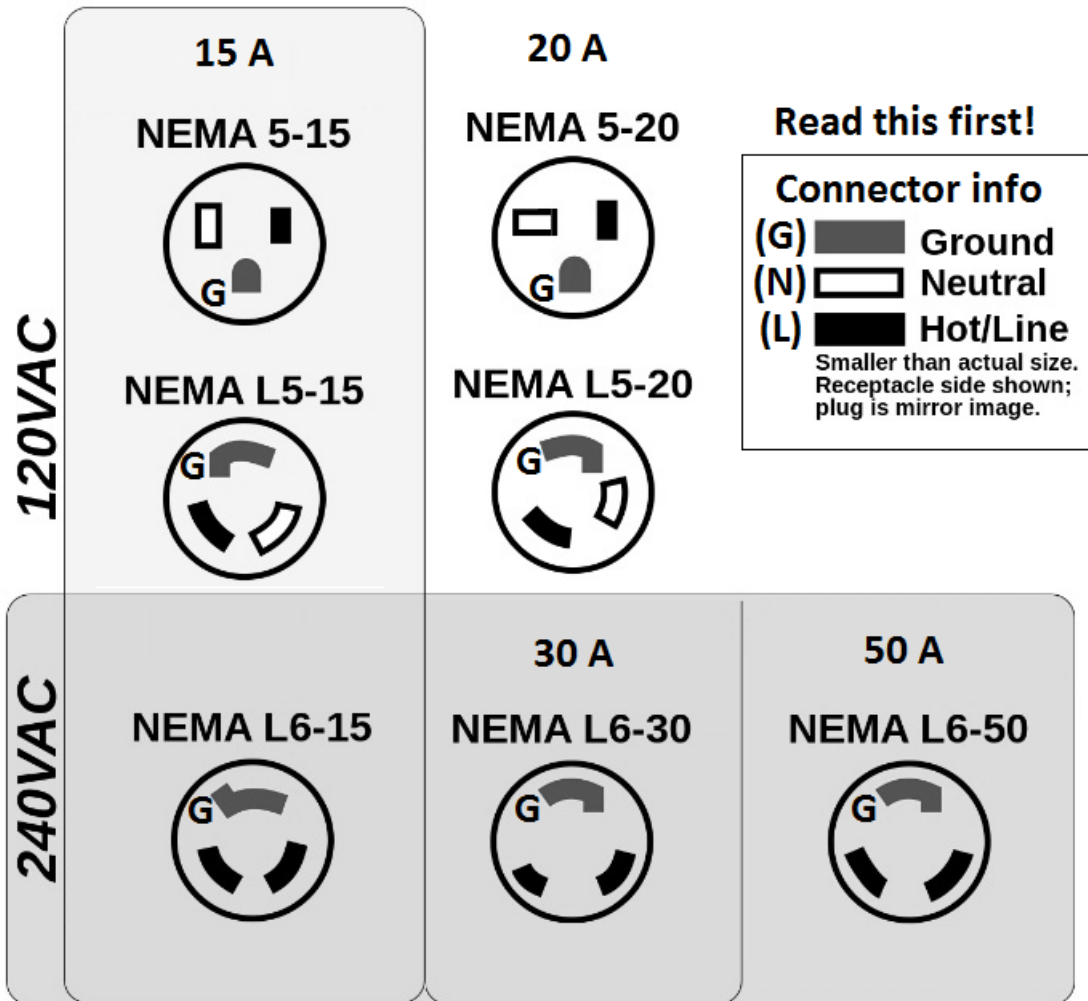

**12. DEKLARATION OM ÖVERENSSTÄMMELSE**  
**12. DECLARATION OF CONFORMITY**  
**12. DECLARATION DE CONFORMITÉ**  
**12. ERKLÄRUNG DER ÜBERSTIMMUNG**  
**12. SAMSVARERKLØRING**

**Pullman Ermator AB**  
**Industrivägen 10**  
**S-777 34 SMEDJEBACKEN**

*Försäkrar under eget ansvar att maskinen*  
*Declare under our sole responsibility that the machine*  
*Certifie sous sa propre responsabilité que le produit ciaprès*  
*Versichern auf eigener verantwortung, dass das Produkt*  
*Forsikrer under eget ansvar at maskinen*

<b>Model</b>	<b>Serial number</b>	<b>M/F year</b>	<b>Model</b>	<b>Serial number</b>	<b>M/F year</b>
S13 120 V	0900058a0001-xxxx	2010-	S36 120 V US	0900242e0001-xxxx	2014-
S13 230 V	0900058 0001-xxxx	2010-	S36 230 V 30A	0900242a0001-xxxx	2010-
S26 120 V	0900256a0001-xxxx	2010-	S36 230 V	0900242 0001-xxxx	2010-
S26 230 V US	0900256b0001-xxxx	2010-			
S26 230 V	0900256 0001-xxxx	2010-			

*som omfattas av denna försäkring är i överensstämmelse med standarder:*  
*included in this declaration, follows the provisions of the:*  
*est conforme aux aux normes suivantes:*  
*den folgenden Normen entspricht:*  
*er i overensstemmelse med standarder:*

**SS-EN 60335-1: 2002+A11+A1+A12+A2+A13+A14**  
**SS-EN 60335-2-69:2009**  
**SS-EN 61000-6-3:2007**  
**SS-EN 61000-6-2:2005**

*enligt villkoren i/according to/selon/aut/i henhold til villkårene i*  
**Machine Directive 2006/42/EC**  
**Low voltage Directive 2006/95/EC**  
**EMC Directive 2004/108/EC**

SMEDJEBACKEN 2016.04.26

**Petra Bengtsson**

# S13 230V, S13 120V

EXPLODED VIEW

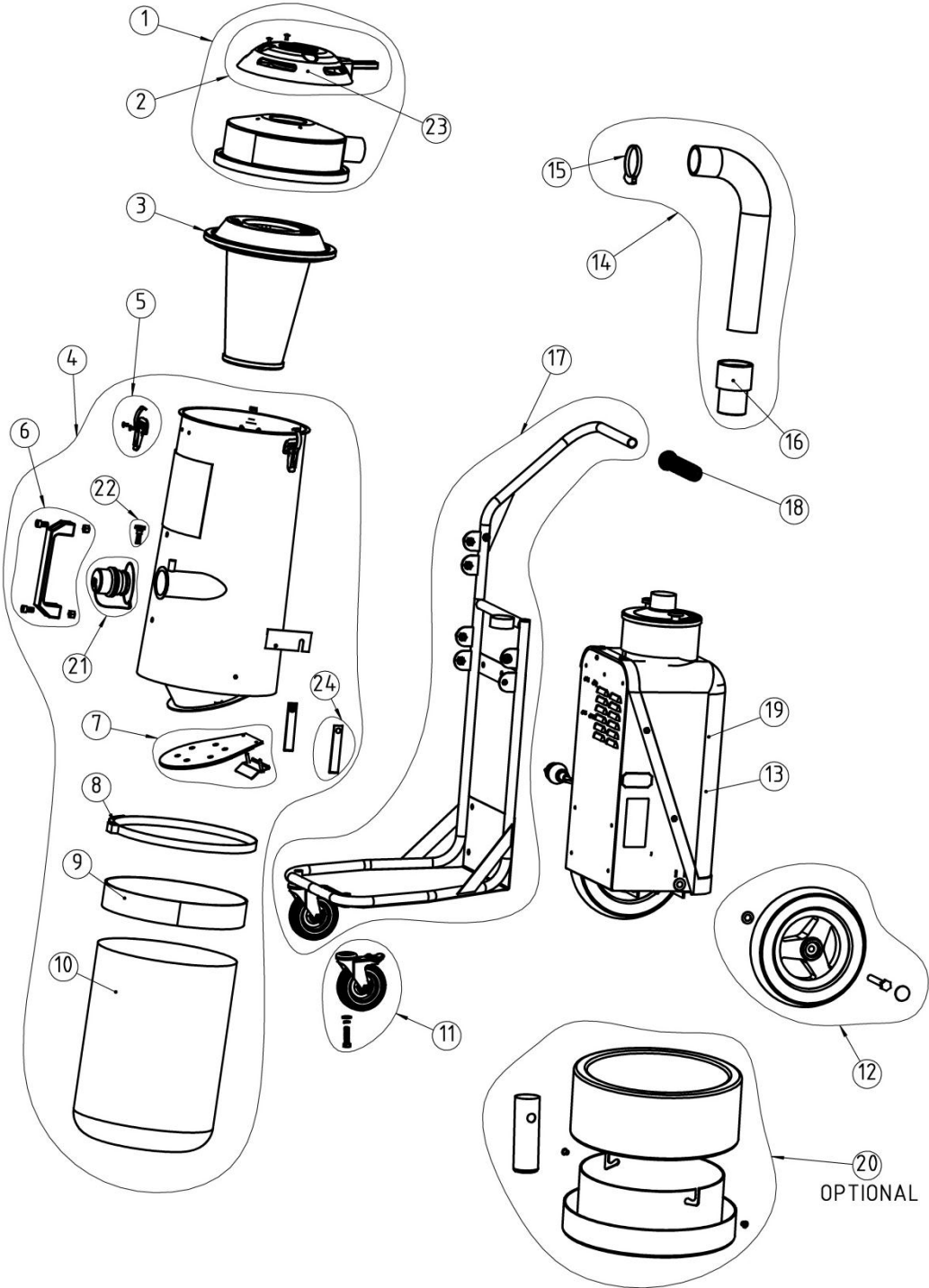

<b>ITEM NO.</b>	<b>QTY.</b>	<b>PART NUMBER</b>	<b>DESCRIPTION</b>
<b>1</b>	<b>1</b>	<b>201000117</b>	<b>TOP COVER ASSEMBLY PACKING (ex.S13)</b>
<b>2</b>	<b>1</b>	<b>201000118</b>	<b>CLEAN UNIT KIT</b>
<b>3</b>	<b>1</b>	<b>201000016</b>	<b>FILTER</b>
<b>4</b>	<b>1</b>	<b>201000119</b>	<b>TANK COMPLETE (ex.S13)</b>
<b>5</b>	<b>3</b>	<b>200600799</b>	<b>HOLDER KIT</b>
<b>6</b>	<b>1</b>	<b>201000120</b>	<b>HANDLE KIT</b>
<b>7</b>	<b>1</b>	<b>201000116</b>	<b>FLAP ASSEMBLY KIT</b>
<b>8</b>	<b>1</b>	<b>201100140</b>	<b>BELT PACKING</b>
<b>9</b>	<b>1</b>	<b>201100141</b>	<b>ANTI-SKID PACKING</b>
<b>10</b>	<b>1</b>	<b>12760008</b>	<b>PLASTIC BAG 25PACK</b>
<b>11</b>	<b>1</b>	<b>200800152</b>	<b>FRONT WHEEL KIT</b>
<b>12</b>	<b>1</b>	<b>200800151</b>	<b>REAR WHEEL KIT</b>
<b>13</b>	<b>1</b>	<b>201100146</b>	<b>ENGINE PACK 230V PACKING</b>
<b>14</b>	<b>1</b>	<b>201000123</b>	<b>HOSE KET S13 PACKING</b>
<b>15</b>	<b>1</b>	<b>201100137</b>	<b>HOSE CLAMP60-65MM PACKING</b>
<b>16</b>	<b>1</b>	<b>201100125</b>	<b>HOSE END A51B PACKING</b>
<b>17</b>	<b>1</b>	<b>201000124</b>	<b>WAGON COMPLETE PACKING</b>
<b>18</b>	<b>1</b>	<b>201100138</b>	<b>HANDLE WAGON (ex. S13) PACKING</b>
<b>19</b>	<b>1</b>	<b>201100146a</b>	<b>ENGINE PACK 120V PACKING</b>
<b>20</b>	<b>1</b>	<b>201000115</b>	<b>LONGOPAC KIT PACKING</b>
<b>21</b>	<b>1</b>	<b>201000122</b>	<b>INLET SEAL COMPLETE SET PACKING</b>
<b>22</b>	<b>1</b>	<b>201100139</b>	<b>LOCKING DEVICE PACKING</b>
<b>23</b>	<b>1</b>	<b>201000670</b>	<b>TOP COVER KIT ex. CLEAN UNIT</b>
<b>24</b>	<b>1</b>	<b>201500174</b>	<b>BELT HOLDER KIT (ex.S13)</b>

# S13 230V

MOTOR PACKAGE

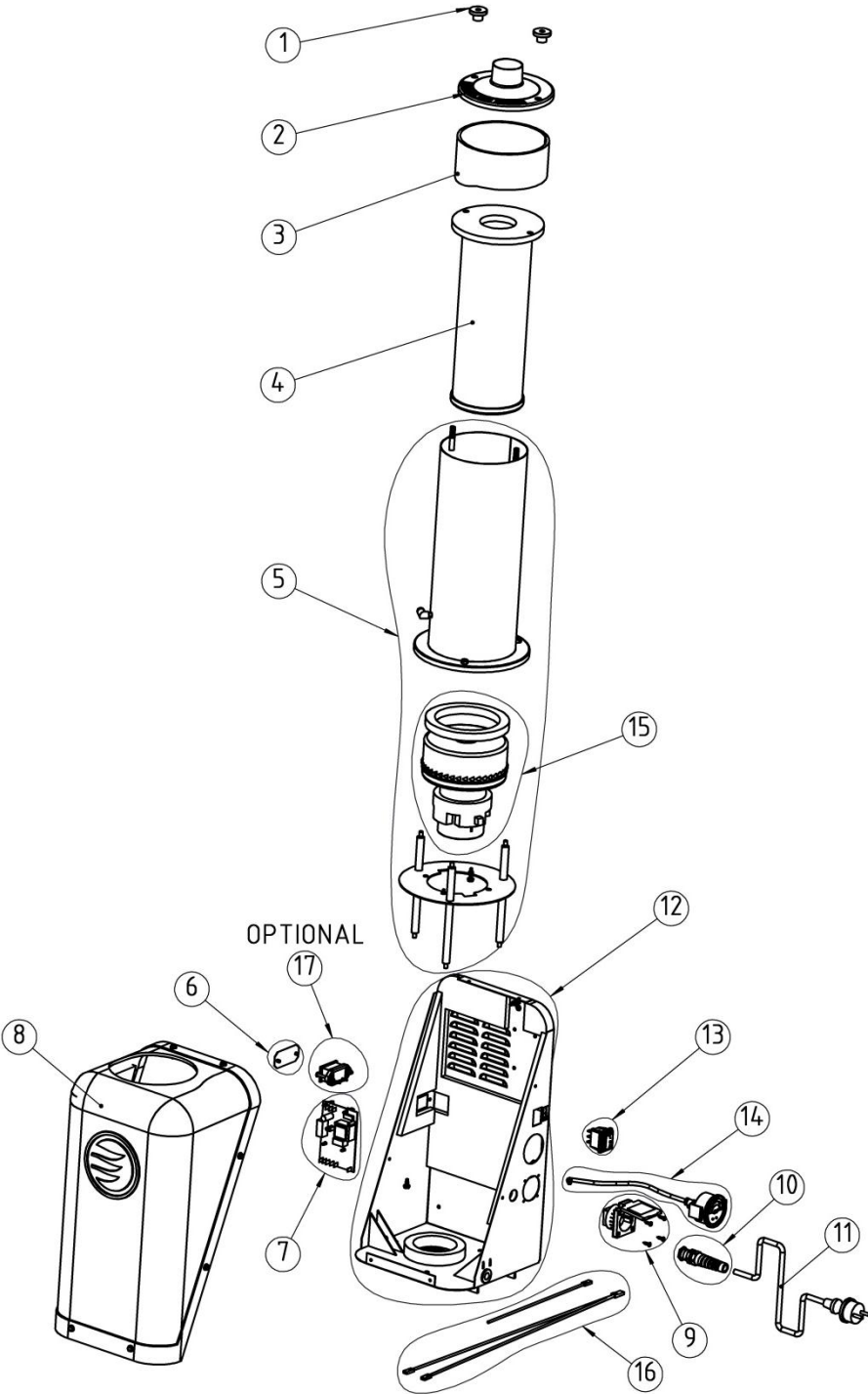

<b>POS.</b>	<b>QTY</b>	<b>NUMBER</b>	<b>DESCRIPTION</b>
<b>1</b>	<b>2</b>	<b>201100128</b>	<b>NUT</b>
<b>2</b>	<b>1</b>	<b>201000121</b>	<b>FILTER COVER KIT</b>
<b>3</b>	<b>1</b>	<b>201100127</b>	<b>SEALING PACKING</b>
<b>4</b>	<b>1</b>	<b>200700070</b>	<b>HEPA FILTER S-LINE</b>
<b>5</b>	<b>1</b>	<b>201100144</b>	<b>ENGINE TUBE KIT (WITH NIPPLE ) PACKING</b>
<b>6</b>	<b>1</b>	<b>201100129</b>	<b>COUNTER COVER PACKING</b>
<b>7</b>	<b>1</b>	<b>201000764</b>	<b>CIRCUIT BOARD KIT</b>
<b>8</b>	<b>1</b>	<b>200600482</b>	<b>ENGINE COVER, KIT</b>
<b>9</b>	<b>1</b>	<b>200600408</b>	<b>ELECTRICAL OUTLET KIT</b>
<b>10</b>	<b>1</b>	<b>201000141</b>	<b>CABLE FIX KIT (PG11)</b>
<b>11</b>	<b>1</b>	<b>201100132</b>	<b>CORD SET PACKING</b>
<b>12</b>	<b>1</b>	<b>201000134</b>	<b>CHASSI COMPLETE KIT</b>
<b>13</b>	<b>1</b>	<b>201100236</b>	<b>SWITCH PACKING</b>
<b>14</b>	<b>1</b>	<b>200700413</b>	<b>MANOMETER, KIT</b>
<b>15</b>	<b>1</b>	<b>200800060</b>	<b>MOTOR KIT 230V KIT</b>
<b>16</b>	<b>1</b>	<b>201100147</b>	<b>CABLE KIT (ex.S13)</b>
<b>17</b>	<b>1</b>	<b>201000133</b>	<b>COUNTER KIT (OPTIONAL S13)</b>

# S13 120V

MOTOR PACKAGE

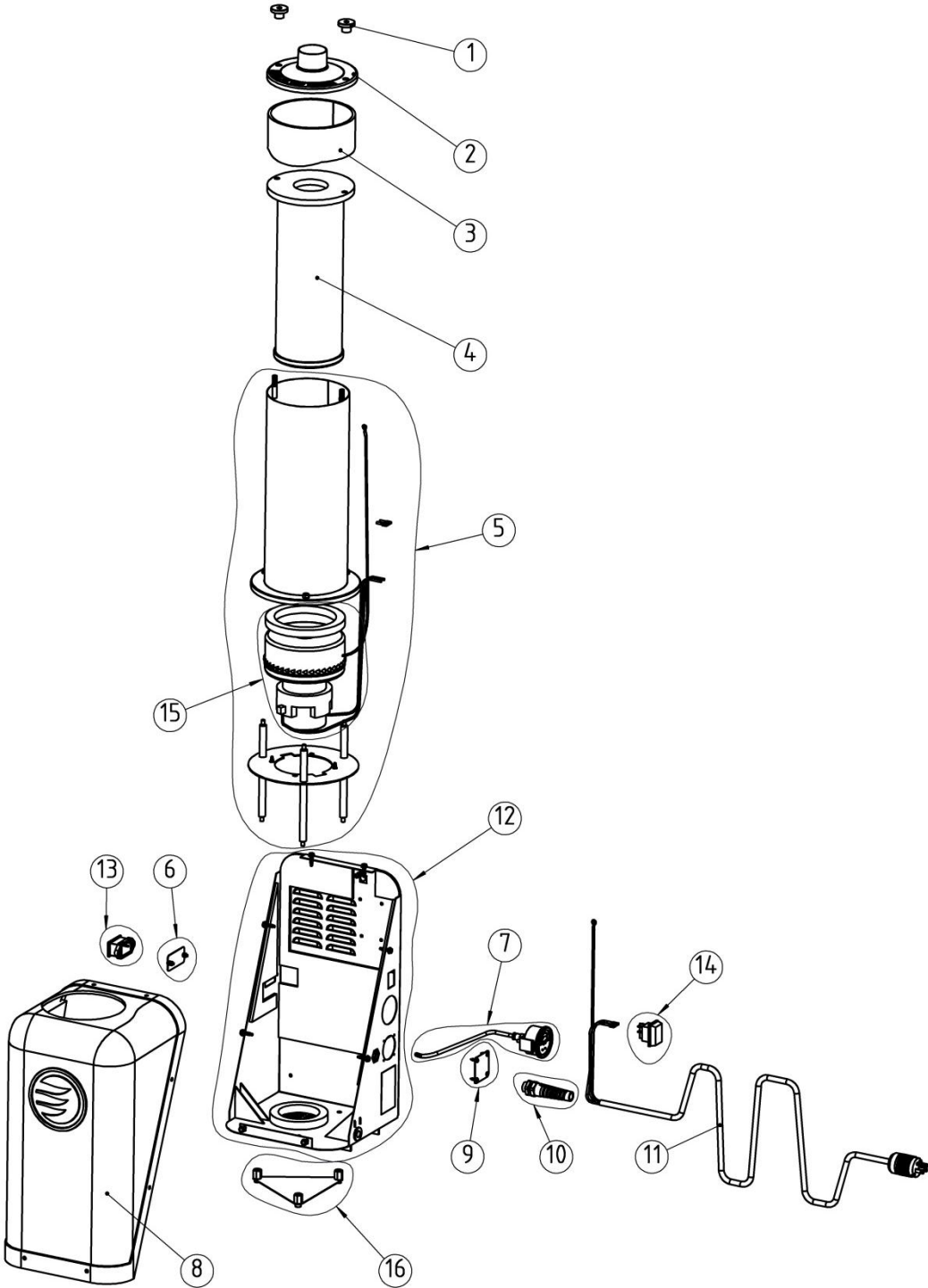

<b>POS.</b>	<b>QTY</b>	<b>NUMBER</b>	<b>DESCRIPTION</b>
<b>1</b>	<b>2</b>	<b>201100128</b>	<b>NUT</b>
<b>2</b>	<b>1</b>	<b>201000121</b>	<b>FILTER COVER KIT</b>
<b>3</b>	<b>1</b>	<b>201100127</b>	<b>SEALING PACKING</b>
<b>4</b>	<b>1</b>	<b>200700070a</b>	<b>HEPA FILTER S-LINE USA</b>
<b>5</b>	<b>1</b>	<b>201100144a</b>	<b>ENGINE TUBE KIT (WITH NIPPLE ) PACKING US</b>
<b>6</b>	<b>1</b>	<b>201100129a</b>	<b>COUNTER COVER PACKING(STEEL VERSION)</b>
<b>7</b>	<b>1</b>	<b>200700413</b>	<b>MANOMETER, KIT</b>
<b>8</b>	<b>1</b>	<b>200600482a</b>	<b>ENGINE COVER ETL VERSION, KIT</b>
<b>9</b>	<b>1</b>	<b>201100148a</b>	<b>OUTLET COVER KIT (STEEL VERSION)</b>
<b>10</b>	<b>1</b>	<b>201100150</b>	<b>CABLE FIX KIT (PG13)</b>
<b>11</b>	<b>1</b>	<b>201500176</b>	<b>CORD SET PACKING (NEMA 5-15P)</b>
<b>12</b>	<b>1</b>	<b>201000134a</b>	<b>CHASSI ETL VERSION COMPLETE KIT</b>
<b>13</b>	<b>1</b>	<b>201000133</b>	<b>COUNTER KIT (OPTIONAL S13)</b>
<b>14</b>	<b>1</b>	<b>201100151</b>	<b>SWITCH PACKING 120V</b>
<b>15</b>	<b>1</b>	<b>200800227</b>	<b>MOTOR KIT 120V 1200W KIT</b>
<b>16</b>	<b>1</b>	<b>201500175</b>	<b>BOTTOM COVER KIT</b>



# ACCESSORIES S13

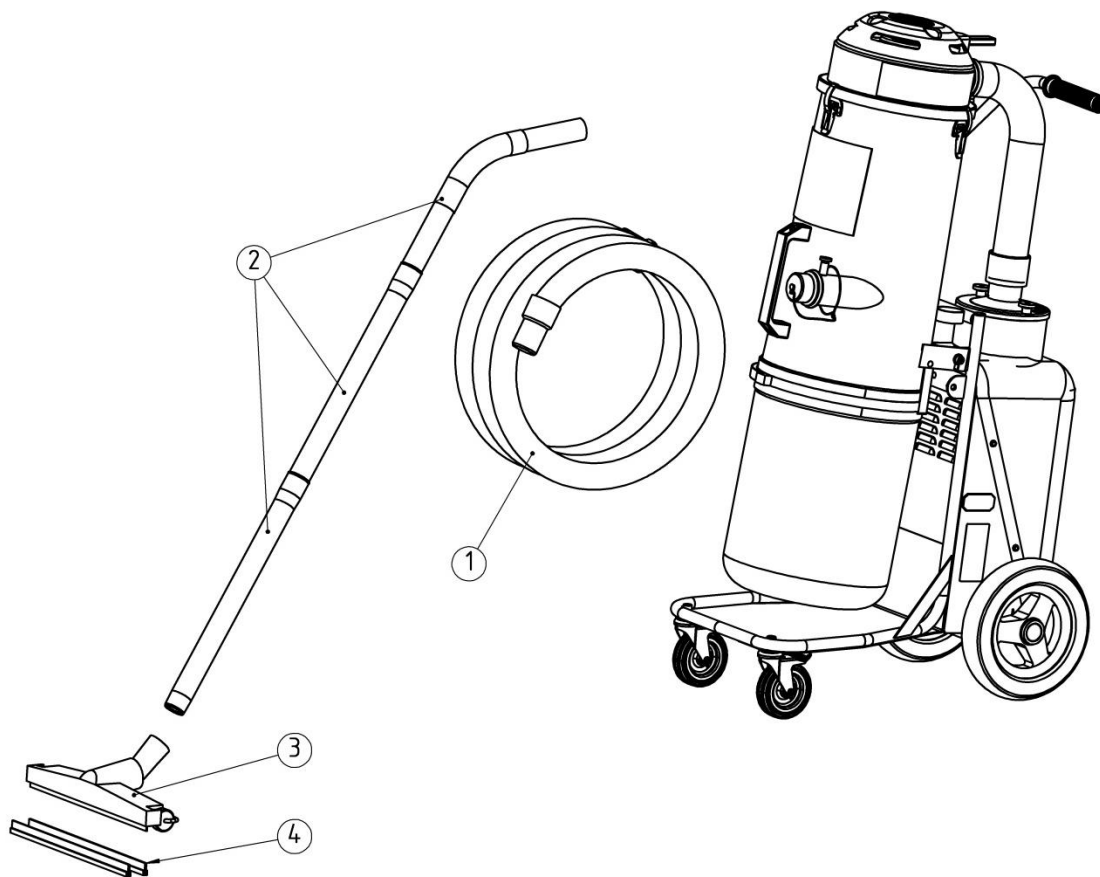

POS.	QTY	NUMBER	DESCRIPTION
1	1	200900281	HOSE 38mm x 4m
2	1	6324034	KC004 SUCTION PIPE
3	1	1326054	GRD370 FLOOR TOOL
4	1	1340011	D370A RUBBER BLADES

# S26 230V, S26 120V, S26 230V US

EXPLODED VIEW

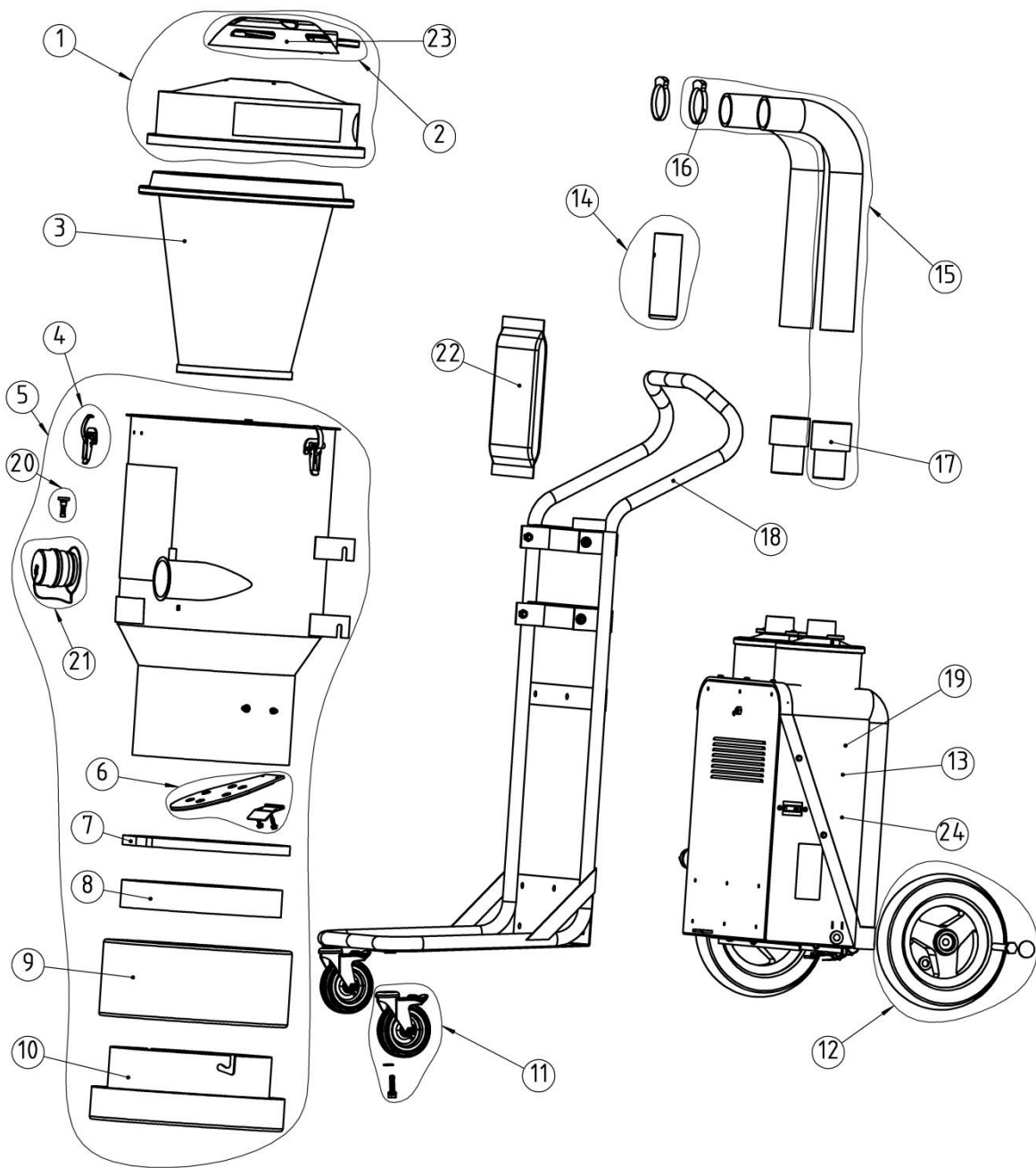

<b>POS.</b>	<b>QTY.</b>	<b>NUMBER</b>	<b>DESCRIPTION</b>
1	1	201000143	TOP COVER KIT (ex.S26)
2	1	201000118	CLEAN UNIT ASSEMBLY PACKING
3	1	200900050	MAIN FILTER
4	3	200600799	HOLDER KIT
5	1	201000129	TANK COMPLETE PACKING (ex. S26)
6	1	201000116	FLAP KIT
7	1	201100140	BELT PACKING
8	1	201100141	ANTI-SKID PACKING
9	1	1376013	LONGOPAC BAG 4 PACK
10	1	201100135	LONGOPAC HOLDER PACKING
11	1	200800152	FRONT WHEEL KIT
12	1	200800151	REAR WHEEL KIT
13	1	201000130	ENGINE PACK KIT PACKING (ex.S26 230V)
14	1	200800153	CLIP HOLDER KIT
15	2	201000144	HOSE KIT S26
16	2	201100137	HOSE CLAMP 60-65 PACKING
17	2	201100125	HOSE END (51MM) PACKING
18	1	201000831	WAGON COMPLETE PACKING
19	1	201000130a	ENGINE PACK KIT PACKING (ex.S26 120V)
20	1	201100139	LOCKING DEVICE PACKING
21	1	201000145	INLET SEAL COMPLETE SET (ex.S26)
22	1	95102	LONGOPAC SEAL CLIPS(60 PCS)
23	1	201000670	PLASTIC COVER KIT (ex. CLEAN UNIT)
24	1	201000130b	ENGINE PACK KIT PACKING (ex.S26 230V US)

# S26 230V

MOTOR PACKAGE

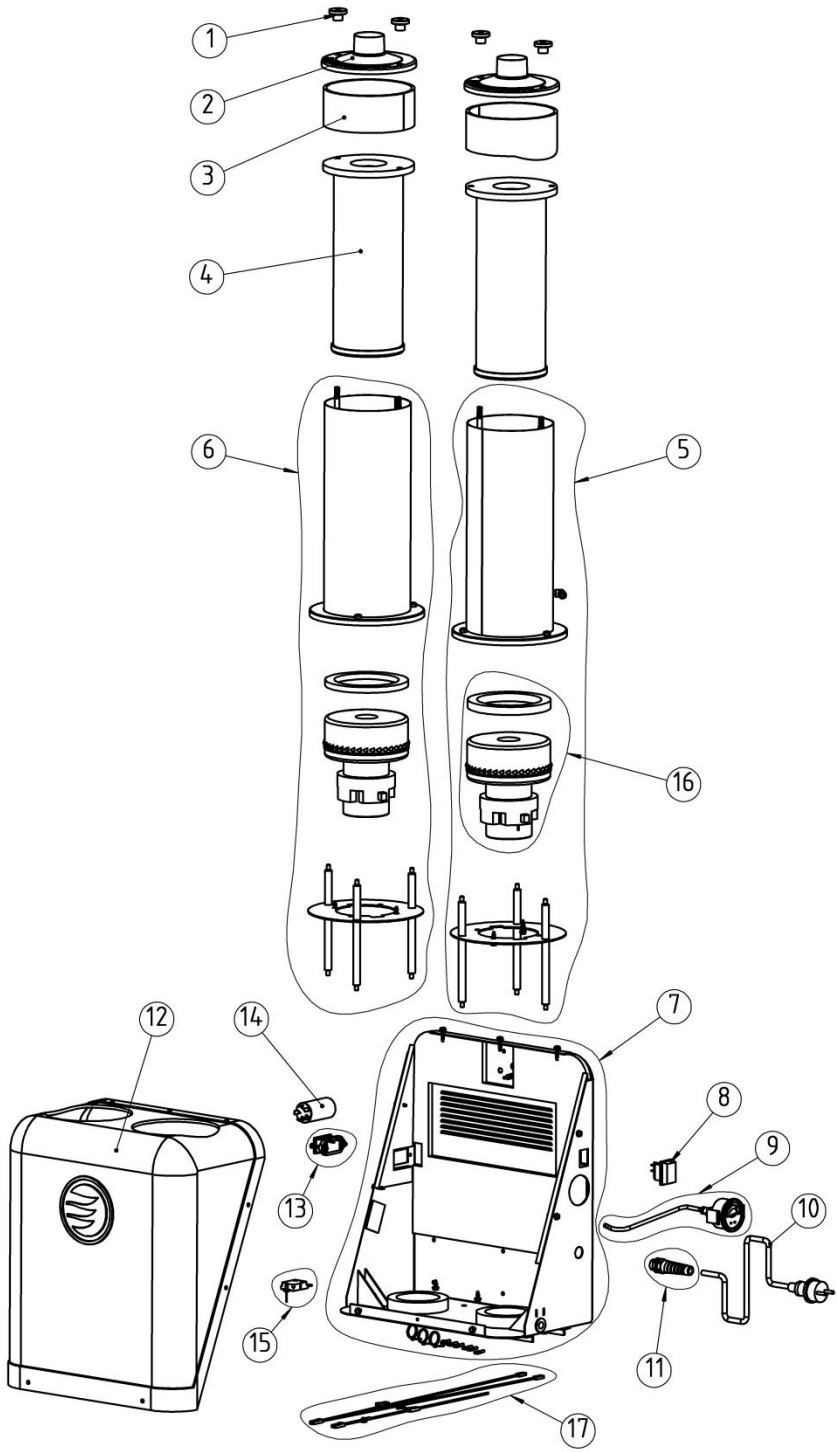

<b>Pos.</b>	<b>QTY.</b>	<b>NUMBER</b>	<b>DESCRIPTION</b>
<b>1</b>	<b>4</b>	<b>201100128</b>	<b>NUT</b>
<b>2</b>	<b>2</b>	<b>201000121</b>	<b>FILTER COVER KIT</b>
<b>3</b>	<b>2</b>	<b>201100127</b>	<b>SEALING PACKING</b>
<b>4</b>	<b>2</b>	<b>200700070</b>	<b>HEPA FILTER S-LINE</b>
<b>5</b>	<b>1</b>	<b>201100144</b>	<b>ENGINE TUBE (WITH NIPPLE) PACKING 230V</b>
<b>6</b>	<b>1</b>	<b>201100152</b>	<b>ENGINE TUBE (WITHOUT NIPPLE) PACKING 230V</b>
<b>7</b>	<b>1</b>	<b>201000135</b>	<b>CHASSIS KIT</b>
<b>8</b>	<b>1</b>	<b>201100151</b>	<b>SWITCH PACKING</b>
<b>9</b>	<b>1</b>	<b>200700413</b>	<b>MANOMETER, KIT</b>
<b>10</b>	<b>1</b>	<b>201100132</b>	<b>CORD SET PACKING</b>
<b>11</b>	<b>1</b>	<b>201000141</b>	<b>CABLE FIX KIT (PG11)</b>
<b>12</b>	<b>1</b>	<b>200600805</b>	<b>ENGINE COVER , KIT</b>
<b>13</b>	<b>1</b>	<b>201000133</b>	<b>COUNTER, KIT</b>
<b>14</b>	<b>1</b>	<b>201100158</b>	<b>ELECTRICAL FILTER</b>
<b>15</b>	<b>1</b>	<b>200700410</b>	<b>SOFT START 230V, KIT</b>
<b>16</b>	<b>2</b>	<b>200800060</b>	<b>MOTOR 230V KIT</b>
<b>17</b>	<b>1</b>	<b>201100157</b>	<b>CABLE KIT 230V</b>

# S26 120V

MOTOR PACKAGE

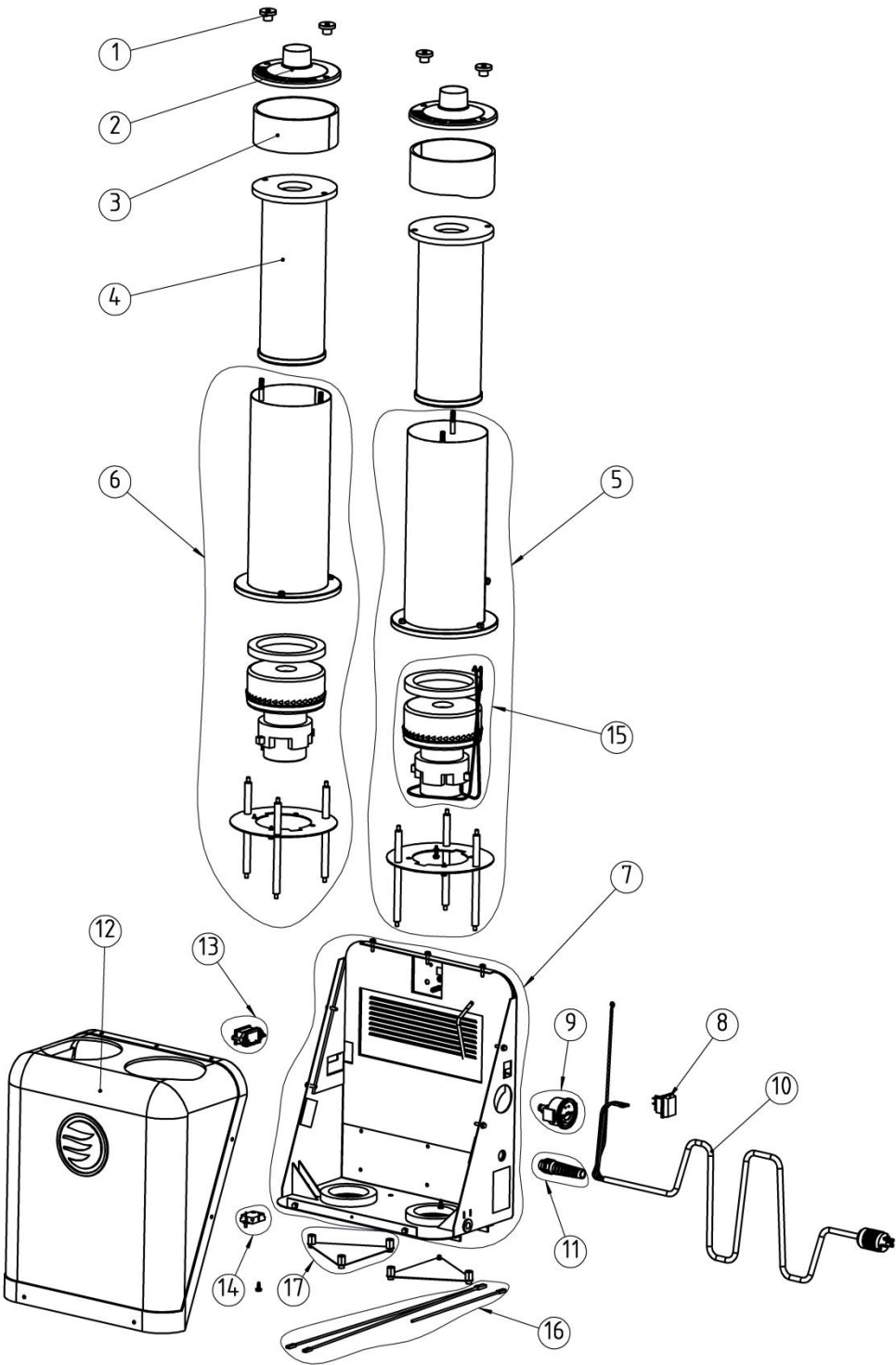

<b>Pos.</b>	<b>QTY.</b>	<b>NUMBER</b>	<b>DESCRIPTION</b>
1	4	201100128	NUT
2	2	201000121	FILTER COVER KIT
3	2	201100127	SEALING PACKING
4	2	200700070a	HEPA FILTER S-LINE USA
5	1	201100144a	ENGINE TUBE (WITH NIPPLE) PACKING 120V
6	1	201100152a	ENGINE TUBE (WITHOUT NIPPLE) PACKING 120V
7	1	201000135a	CHASSIS ETL VERSION KIT
8	1	201100151	SWITCH PACKING
9	1	200700413	MANOMETER, KIT
10	1	201500177	CORD SET PACKING (NEMA 5-20P)
11	1	201100150	CABLE FIX KIT (PG13)
12	1	200600805a	ENGINE COVER ETL VERSION, KIT
13	1	201000133	COUNTER, KIT
14	1	200700531	SOFT START 120V, KIT
15	2	200800227	MOTOR 120V 1200W KIT
16	1	201100157a	CABLE KIT 120V
17	2	201500175	BOTTOM COVER KIT

# S26 230V US

MOTOR PACKAGE

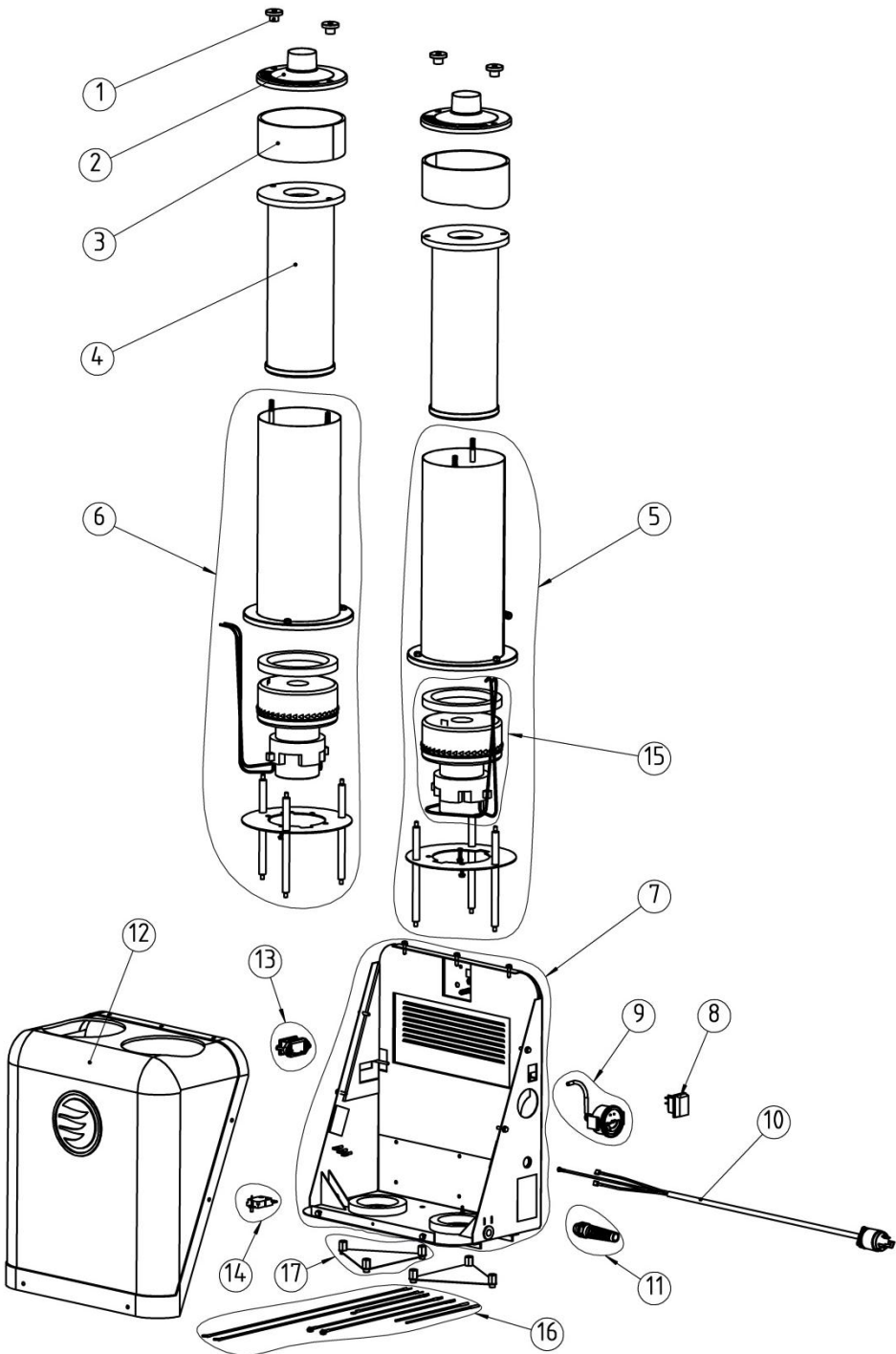



<b>Pos.</b>	<b>QTY.</b>	<b>NUMBER</b>	<b>DESCRIPTION</b>
<b>1</b>	<b>4</b>	<b>201100128</b>	<b>NUT</b>
<b>2</b>	<b>2</b>	<b>201000121</b>	<b>FILTER COVER KIT</b>
<b>3</b>	<b>2</b>	<b>201100127</b>	<b>SEALING PACKING</b>
<b>4</b>	<b>2</b>	<b>200700070a</b>	<b>HEPA FILTER S-LINE USA</b>
<b>5</b>	<b>1</b>	<b>201100144</b>	<b>ENGINE TUBE (WITH NIPPLE) PACKING 230V</b>
<b>6</b>	<b>1</b>	<b>201100152</b>	<b>ENGINE TUBE (WITHOUT NIPPLE) PACKING 230V</b>
<b>7</b>	<b>1</b>	<b>201000135a</b>	<b>CHASSIS ETL VERSION KIT</b>
<b>8</b>	<b>1</b>	<b>201100151</b>	<b>SWITCH PACKING</b>
<b>9</b>	<b>1</b>	<b>200700413</b>	<b>MANOMETER, KIT</b>
<b>10</b>	<b>1</b>	<b>201500178</b>	<b>CORD SET PACKING (NEMA L6-15P)</b>
<b>11</b>	<b>1</b>	<b>201100150</b>	<b>CABLE FIX KIT (PG13)</b>
<b>12</b>	<b>1</b>	<b>200600805a</b>	<b>ENGINE COVER ETL VERSION, KIT</b>
<b>13</b>	<b>1</b>	<b>201000133</b>	<b>COUNTER, KIT</b>
<b>14</b>	<b>1</b>	<b>200700410</b>	<b>SOFT START 230V, KIT</b>
<b>15</b>	<b>2</b>	<b>200800060</b>	<b>MOTOR 230V KIT</b>
<b>16</b>	<b>1</b>	<b>201100157a</b>	<b>CABLE KIT 120V</b>
<b>17</b>	<b>2</b>	<b>201500175</b>	<b>BOTTOM COVER KIT</b>

# ACCESSORIES S26

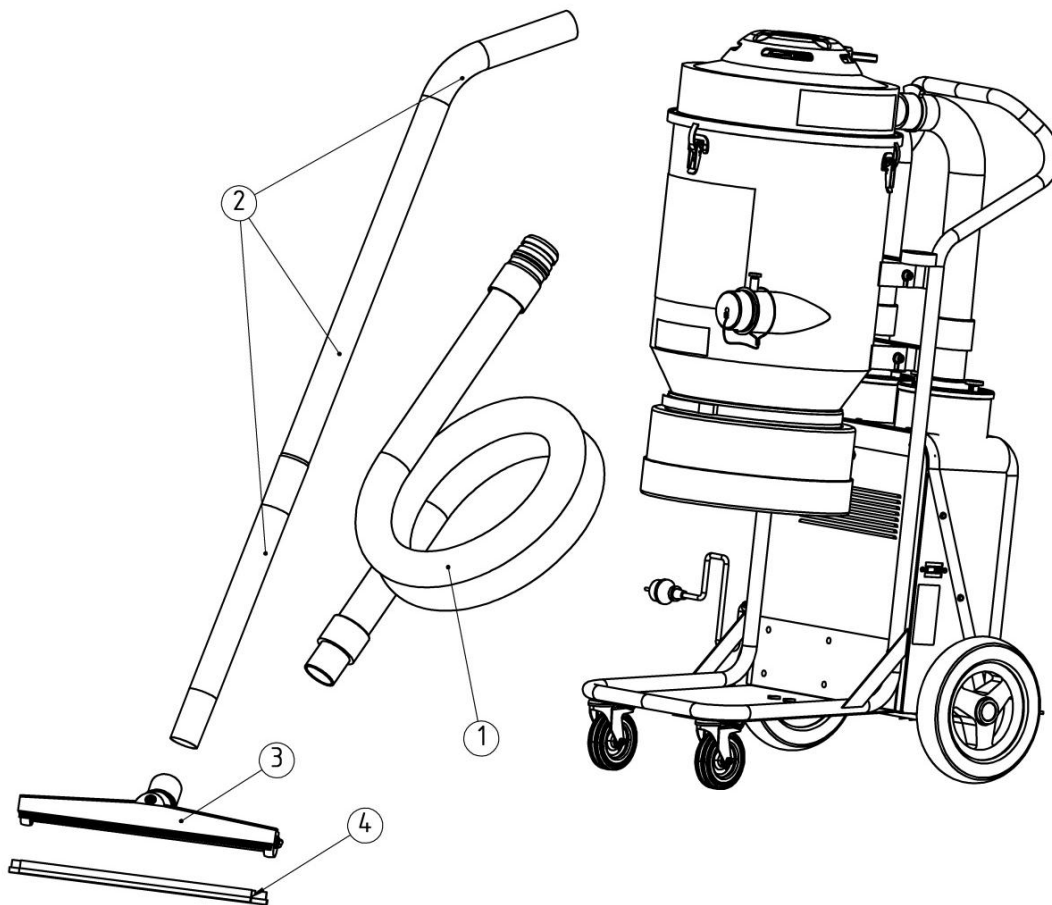

POS.	QTY	NUMBER	DESCRIPTION
1	1	200900288	HOSE 51mm x 4m (ex. S26 230V)
(1)	1	201000061	HOSE 51mm x 7,5m (ex. S26 120V)
2	1	1224035	50S WAND 51mm
3	1	1326087	S450 FLOOR TOOL 50mm x 450mm
4	1	1340005	AG46A BRUSHES (L=400/445)

# S36 230V

EXPLODED VIEW

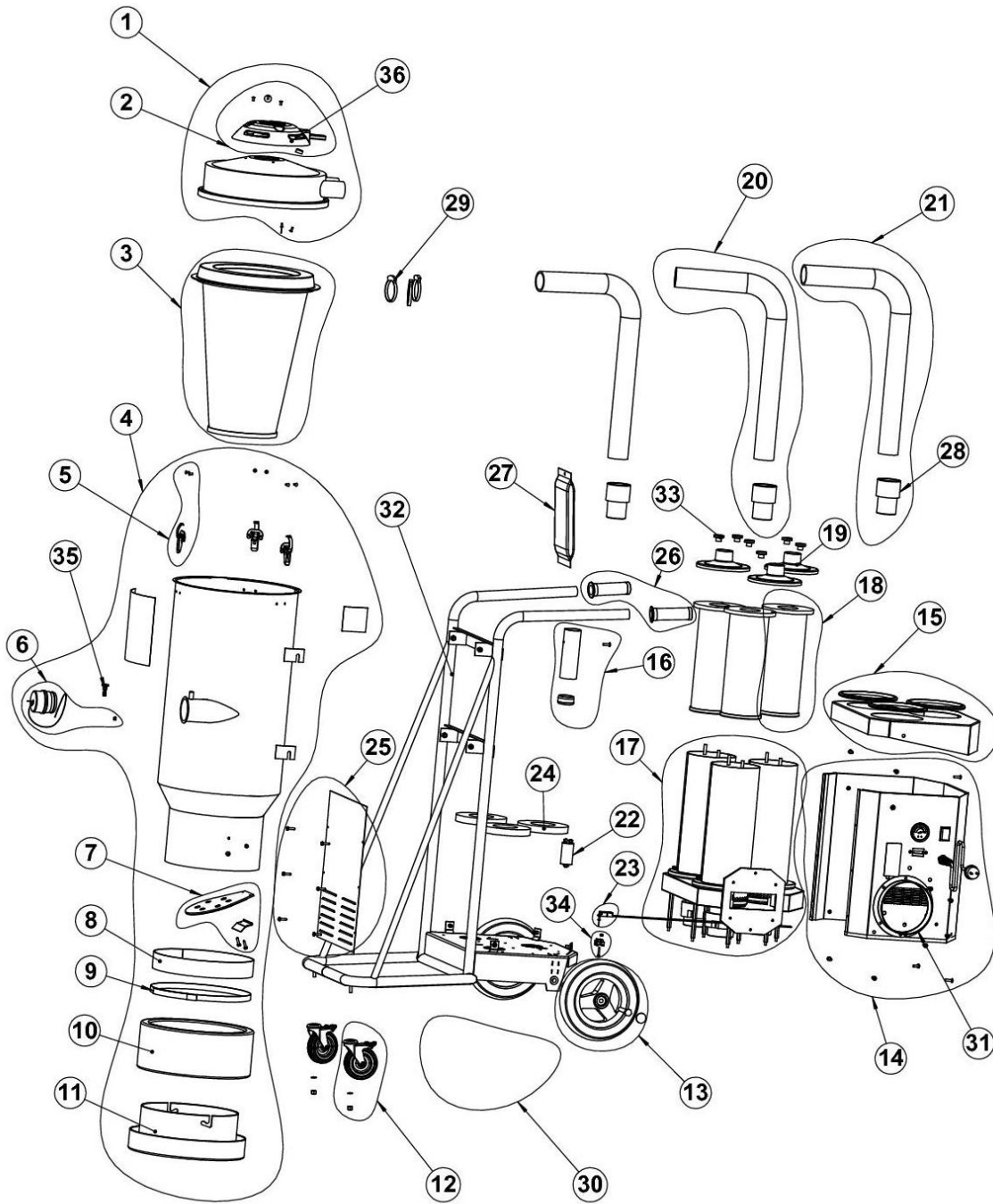

<b>POS.</b>	<b>QTY.</b>	<b>NUMBER</b>	<b>DESCRIPTION</b>
1	1	201100160	TOP COVER PACKING (ex. S36)
2	1	201000118	CLEAN UNIT ASSEMBLY PACKING
3	1	200900051	FILTER
4	1	201000200	TANK COMPLETE (ex. S36)
5	3	200600799	HOLDER KIT
6	1	201000145	INLET SEAL COMPLETE SET
7	1	201000116	FLAP KIT
8	1	201100141	ANTI-SKID PACKING
9	1	201100140	BELT PACKING
10	1	1376013	LONGOPAC BAG 4 PACK
11	1	201100135	LONGOPAC HOLDER PACKING
12	1	200800152	FRONT WHEEL KIT
13	1	200800151	REAR WHEEL KIT
14	1	201100167	MOTOR COVER ASSEMBLY (ex. S36)
15	1	201000201	TOP MOTOR COVER KIT (ex.S36)
16	1	200800153	CLIP HOLDER KIT
17	1	201100169	MOTOR BOX KIT PACKING
18	3	200700070	HEPA FILTER S-LINE
19	3	201000121	FILTER COVER KIT
20	2	201000203	MIDDLE HOSE KIT OF S36
21	1	201000204	HOSE KIT OF S36
22	1	201100158	ELECTRICAL FILTER
23	1	200700410	SOFT START 230V, KIT
24	3	201100161	INSULATION PACKING
25	1	201000205	PLATE COVER KIT OF MOTOR COVER
26	1	201000206	HANDLE KIT PACKING
27	1	95102	LONGOPAC SEAL CLIPS(60 PCS)
28	3	201100125	HOSE END (51MM) PACKING
29	3	201100137	HOSE CLAMP 60-65 PACKING
30	1	201000207	SCREW AND NUT SET OF S36
31	1	201000208	160MM EXHAUST AIR OUTLET PACKING
32	1	201000209	WAGON ASSEMBLY
33	6	201100128	NUT
34	1	201000210	CONNECTION BRIDGE KIT
35	1	201100139	LOCKING DEVICE PACKING
36	1	201000670	TOP COVER KIT ex. CLEAN UNIT

# S36 230V

MOTOR PACKAGE

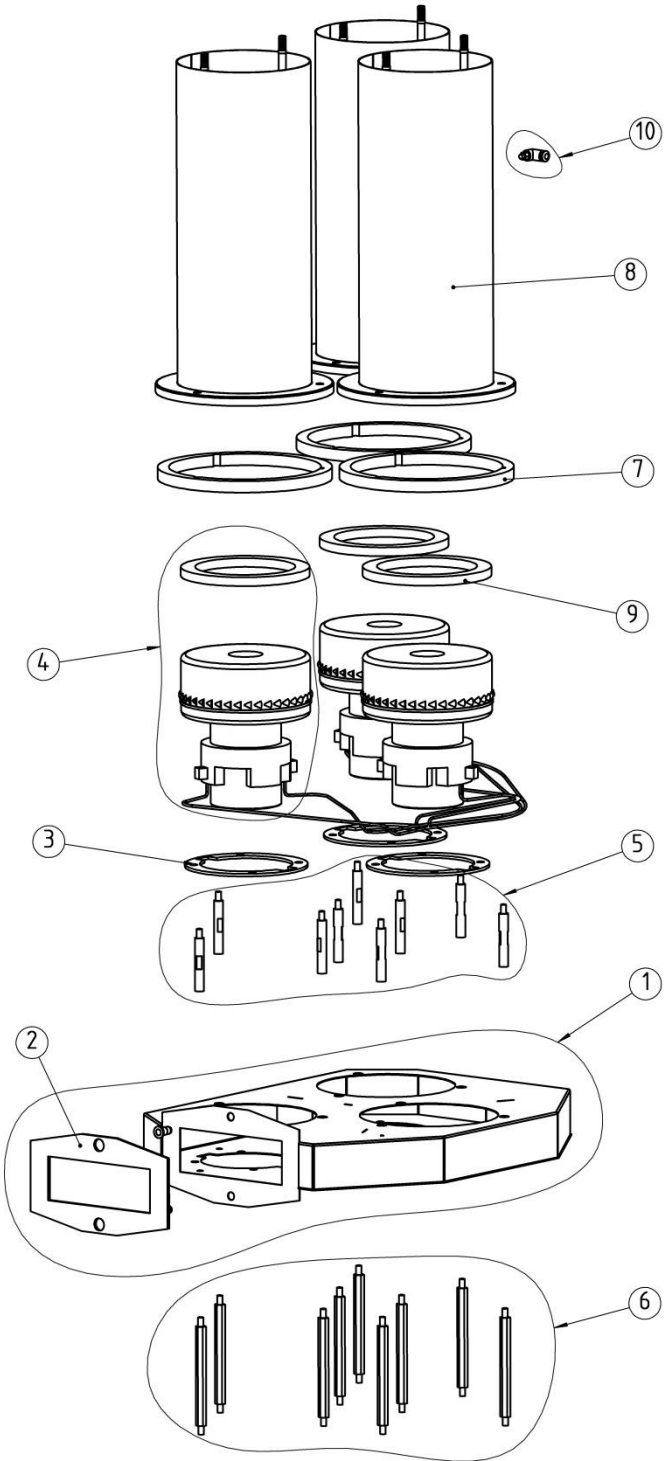

<b>POS.</b>	<b>QTY.</b>	<b>NUMBER</b>	<b>DESCRIPTION</b>
<b>1</b>	<b>1</b>	<b>201100171</b>	<b>MOTOR BOX (ex. S36)</b>
<b>2</b>	<b>1</b>	<b>201100172</b>	<b>SEALING 160 mm OUTLET</b>
<b>3</b>	<b>1</b>	<b>201100173</b>	<b>SEALING PACKING</b>
<b>4</b>	<b>3</b>	<b>200800060</b>	<b>MOTOR 230V KIT</b>
<b>5</b>	<b>1</b>	<b>201100174</b>	<b>UPPER SUPPORT PIN KIT (ex. S36)</b>
<b>6</b>	<b>1</b>	<b>201100175</b>	<b>LOWER SUPPORT PIN KIT (ex. S36)</b>
<b>7</b>	<b>1</b>	<b>201100170</b>	<b>TOP MOTOR SEALING</b>
<b>8</b>	<b>3</b>	<b>201100176</b>	<b>FILTER HOUSING</b>
<b>9</b>	<b>1</b>	<b>201100177</b>	<b>MOTOR SEALING KIT</b>
<b>10</b>	<b>1</b>	<b>201000178</b>	<b>NIPPLE ANGLE KIT</b>

# S36 230V

MOTOR COVER

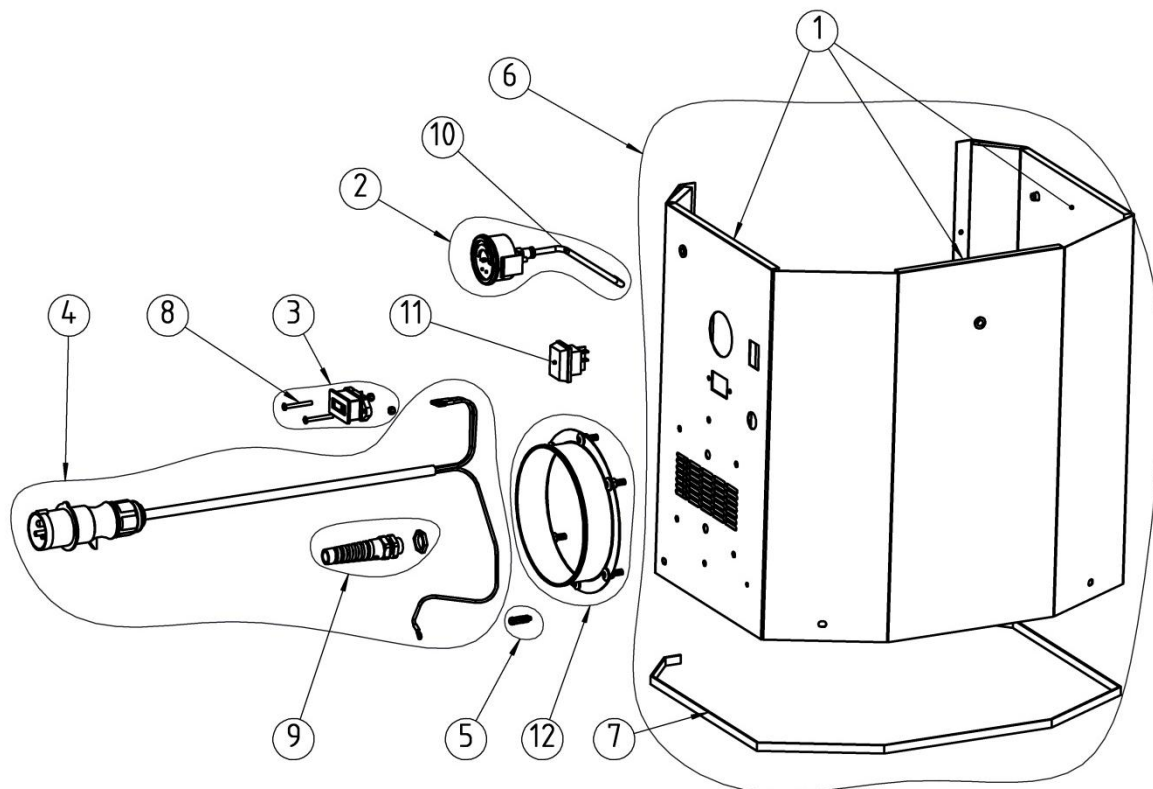

POS.	QTY.	NUMBER	DESCRIPTION
1	1	201100165	AC FOAM PACKING
2	1	200700413	MANOMETER KIT
3	1	201000133	COUNTER SET
4	1	201100149	CORD SET PACKING
5	1	201000211	GROUNDING SCREW KIT
6	1	201000212	MOTOR COVER
7	1	201100163	SEALING PACKING
8	2	201000213	SCREW SET OF COUNTER
9	1	201100150	CABLE FIX KIT (PG13)
10	1	201100164	HOSE PACKING
11	1	201100151	SWITCH PACKING
12	1	201000208	160MM EXHAUST AIR OUTLET PACKING

# S36 230V 30A

EXPLODED VIEW

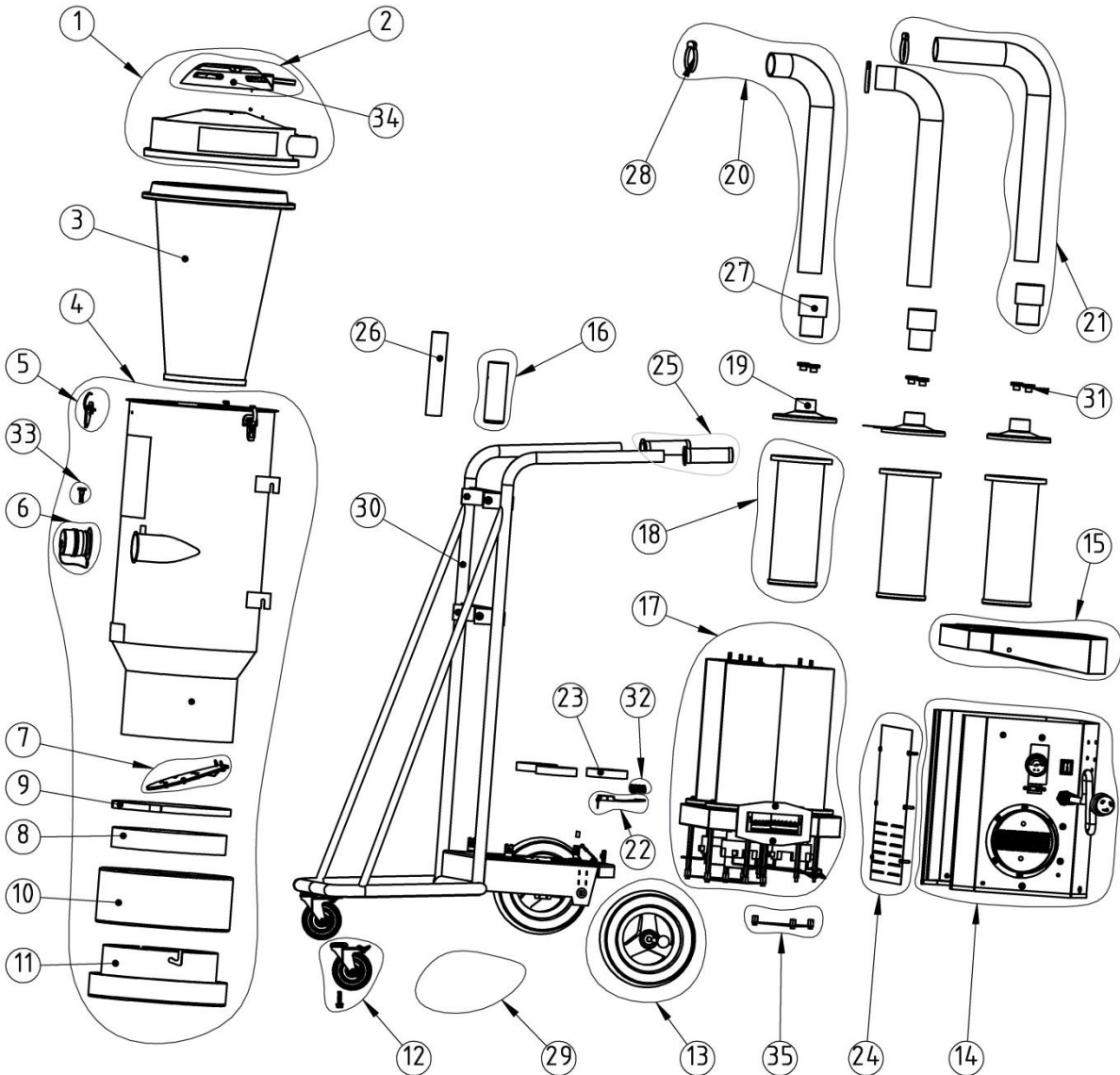



<b>POS.</b>	<b>QTY.</b>	<b>NUMBER</b>	<b>DESCRIPTION</b>
1	1	201100160	TOP COVER PACKING (ex. S36)
2	1	201000118	CLEAN UNIT ASSEMBLY PACKING
3	1	200900051	FILTER
4	1	201000200a	TANK COMPLETE (ex. S36a)
5	3	200600799	HOLDER KIT
6	1	201000145	INLET SEAL COMPLETE SET
7	1	201000116	FLAP KIT
8	1	201100141	ANTI-SKID PACKING
9	1	201100140	BELT PACKING
10	1	1376013	LONGOPAC BAG 4 PACK
11	1	201100135	LONGOPAC HOLDER PACKING
12	1	200800152	FRONT WHEEL KIT
13	1	200800151	REAR WHEEL KIT
14	1	201100167a	MOTOR COVER ASSEMBLY (ex. S36 30 A OUTLET)
15	1	201000201	TOP MOTOR COVER KIT (ex.S36)
16	1	200800153	CLIP HOLDER KIT
17	1	201100169	MOTOR BOX KIT PACKING
18	3	200700070a	HEPA FILTER S-LINE USA
19	3	201000121	FILTER COVER KIT
20	2	201000203	MIDDLE HOSE KIT OF S36
21	1	201000204	HOSE KIT OF S36
22	1	200700410	SOFT START 230V, KIT
23	3	201100161	INSULATION PACKING
24	1	201000205	PLATE COVER KIT OF MOTOR COVER
25	1	201000206	HANDLE KIT PACKING
26	1	95102	LONGOPAC SEAL CLIPS(60 PCS)
27	3	201100125	HOSE END (51MM) PACKING
28	3	201100137	HOSE CLAMP 60-65 PACKING
29	1	201000207	SCREW AND NUT SET OF S36
30	1	201000209	WAGON ASSEMBLY
31	6	201100128	KUNRLED THUMB NUT
32	1	201000210	CONNECTION BRIDGE KIT
33	1	201100139	LOCKING DEVICE PACKING
34	1	201000670	TOP COVER KIT ex. CLEAN UNIT
35	3	201500175	BOTTOM COVER KIT

# S36 230V 30A

MOTOR PACAKAGE

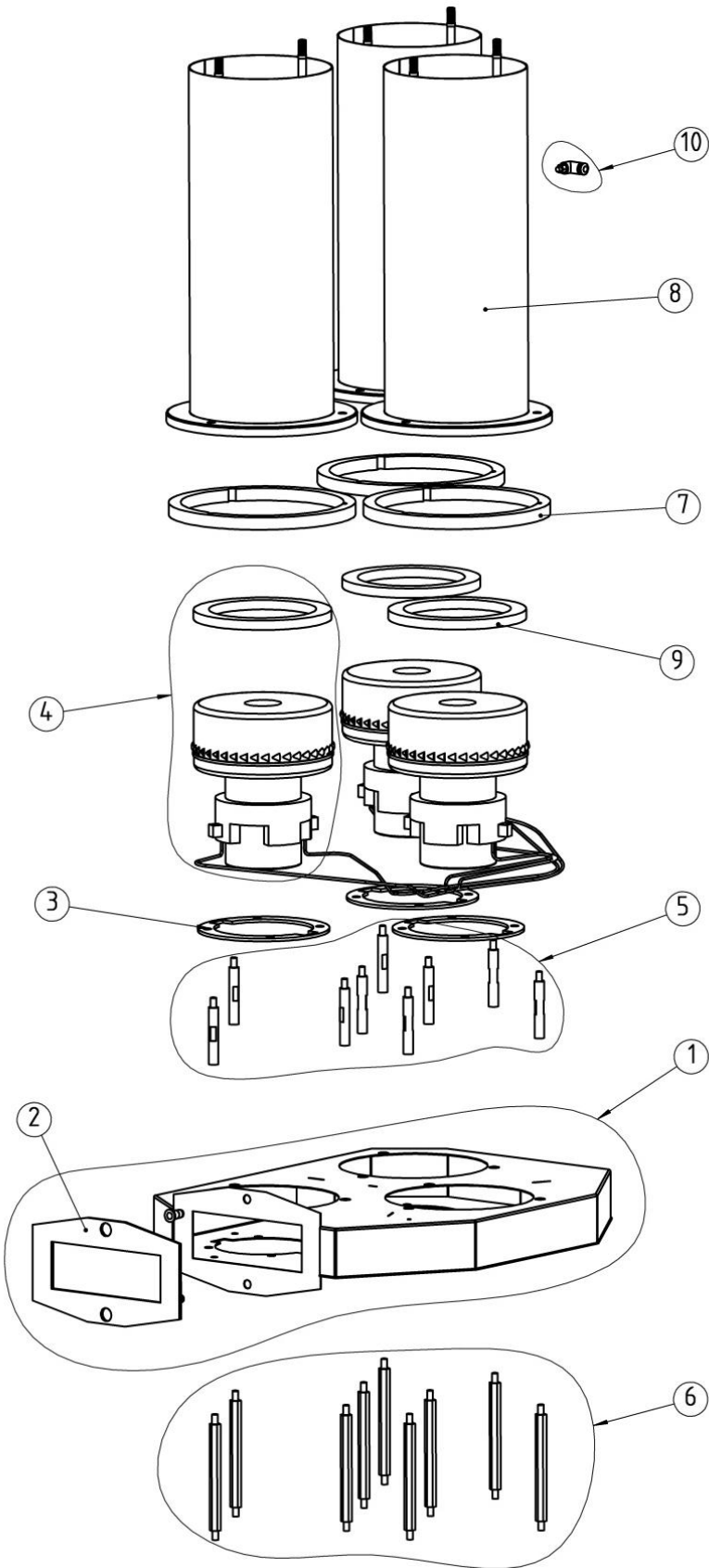

<b>POS.</b>	<b>QTY.</b>	<b>NUMBER</b>	<b>DESCRIPTION</b>
<b>1</b>	<b>1</b>	<b>201100171</b>	<b>MOTOR BOX (ex. S36)</b>
<b>2</b>	<b>1</b>	<b>201100172</b>	<b>SEALING 160 mm OUTLET</b>
<b>3</b>	<b>1</b>	<b>201100173</b>	<b>SEALING PACKING</b>
<b>4</b>	<b>3</b>	<b>200800060</b>	<b>MOTOR 230V KIT</b>
<b>5</b>	<b>1</b>	<b>201100174</b>	<b>UPPER SUPPORT PIN KIT (ex. S36)</b>
<b>6</b>	<b>1</b>	<b>201100175</b>	<b>LOWER SUPPORT PIN KIT (ex. S36)</b>
<b>7</b>	<b>1</b>	<b>201100170</b>	<b>TOP MOTOR SEALING</b>
<b>8</b>	<b>3</b>	<b>201100176</b>	<b>FILTER HOUSING</b>
<b>9</b>	<b>1</b>	<b>201100177</b>	<b>MOTOR SEALING KIT</b>
<b>10</b>	<b>1</b>	<b>201000178</b>	<b>NIPPLE ANGLE KIT</b>

# S36 230V 30A

MOTOR COVER

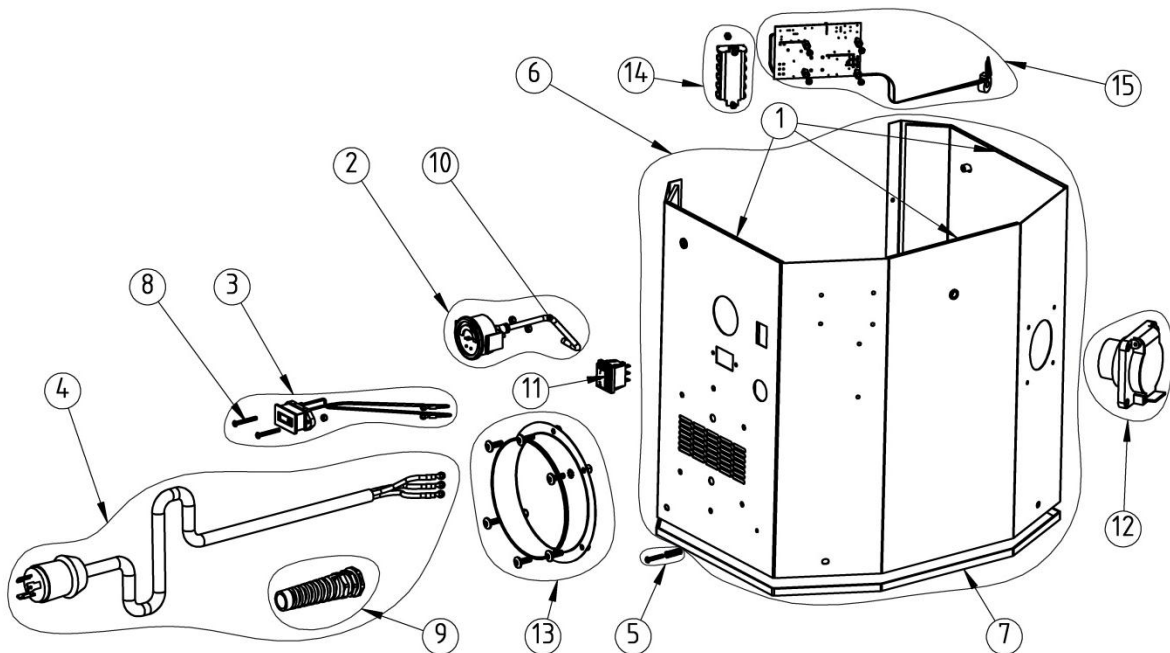

POS.	QTY.	NUMBER	DESCRIPTION
1	1	201100165a	AC FOAM ETL VERSION PACKING
2	1	200700413	MANOMETER KIT
3	1	201000133	COUNTER SET
4	1	201000705	CORD SET KIT (ex. S36 30A OUTLET)
5	1	201000211	GROUNDING SCREW KIT
6	1	201000212a	MOTOR COVER KIT (ex.S36a)
7	1	201100163	SEALING PACKING
8	1	201000213	SCREW SET OF COUNTER
9	1	201500181	CABLE FIX KIT PG21
10	1	201100164	HOSE PACKING
11	1	201100236	SWITCH PACKING
12	1	201000666	ELECTRICAL OUTLET 30A
13	1	201000208	160MM EXHAUST AIR OUTLET PACKING
14	1	201500179	TERMINAL STRIP KIT (ex.S36 30A)
15	1	201500180	PCBA KIT (ex.S36a 30A)

# S36 120V

EXPLODED VIEW

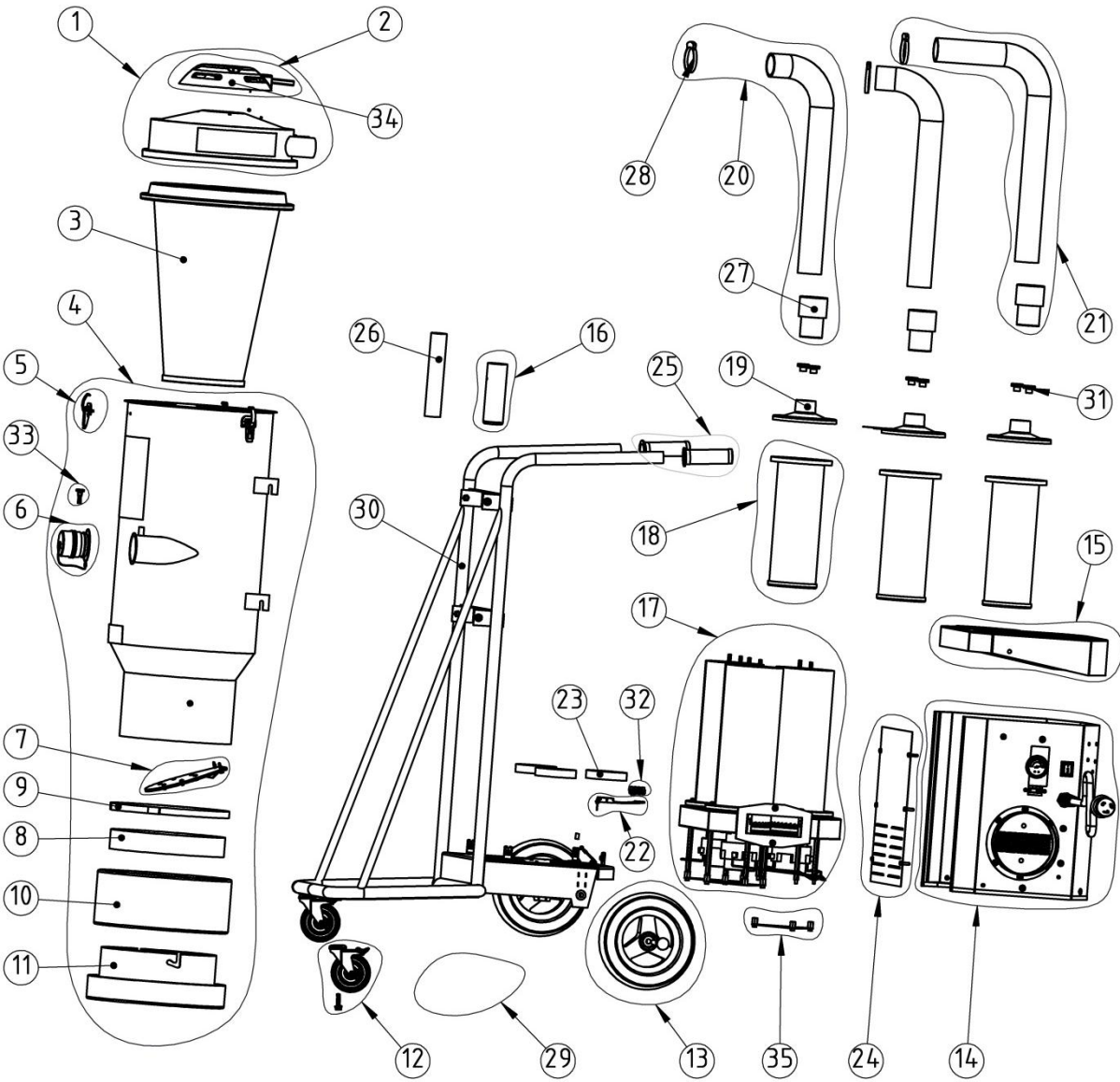

<b>POS.</b>	<b>QTY.</b>	<b>NUMBER</b>	<b>DESCRIPTION</b>
1	1	201100160	TOP COVER PACKING (ex. S36)
2	1	201000118	CLEAN UNIT ASSEMBLY PACKING
3	1	200900051	FILTER
4	1	201000200a	TANK COMPLETE (ex. S36a)
5	3	200600799	HOLDER KIT
6	1	201000145	INLET SEAL COMPLETE SET
7	1	201000116	FLAP KIT
8	1	201100141	ANTI-SKID PACKING
9	1	201100140	BELT PACKING
10	1	1376013	LONGOPAC BAG 4 PACK
11	1	201100135	LONGOPAC HOLDER PACKING
12	1	200800152	FRONT WHEEL KIT
13	1	200800151	REAR WHEEL KIT
14	1	201100167e	MOTOR COVER ASSEMBLY (ex. S36 USA 120V)
15	1	201000201	TOP MOTOR COVER KIT (ex.S36)
16	1	200800153	CLIP HOLDER KIT
17	1	201100169e	MOTOR BOX KIT(ex.S36 USA 120V)
18	3	200700070a	HEPA FILTER S-LINE USA
19	3	201000121	FILTER COVER KIT
20	2	201000203	MIDDLE HOSE KIT OF S36
21	1	201000204	HOSE KIT OF S36
22	1	200700410	SOFT START 230V, KIT
23	3	201100161	INSULATION PACKING
24	1	201000205	PLATE COVER KIT OF MOTOR COVER
25	1	201000206	HANDLE KIT PACKING
26	1	95102	LONGOPAC SEAL CLIPS(60 PCS)
27	3	201100125	HOSE END (51MM) PACKING
28	3	201100137	HOSE CLAMP 60-65 PACKING
29	1	201000207	SCREW AND NUT SET OF S36
30	1	201000209	WAGON ASSEMBLY
31	6	201100128	KUNRLED THUMB NUT
32	1	201000210	CONNECTION BRIDGE KIT
33	1	201100139	LOCKING DEVICE PACKING
34	1	201000670	TOP COVER KIT ex. CLEAN UNIT
35	3	201500175	BOTTOM COVER KIT

# S36 120V

MOTOR PACKAGE

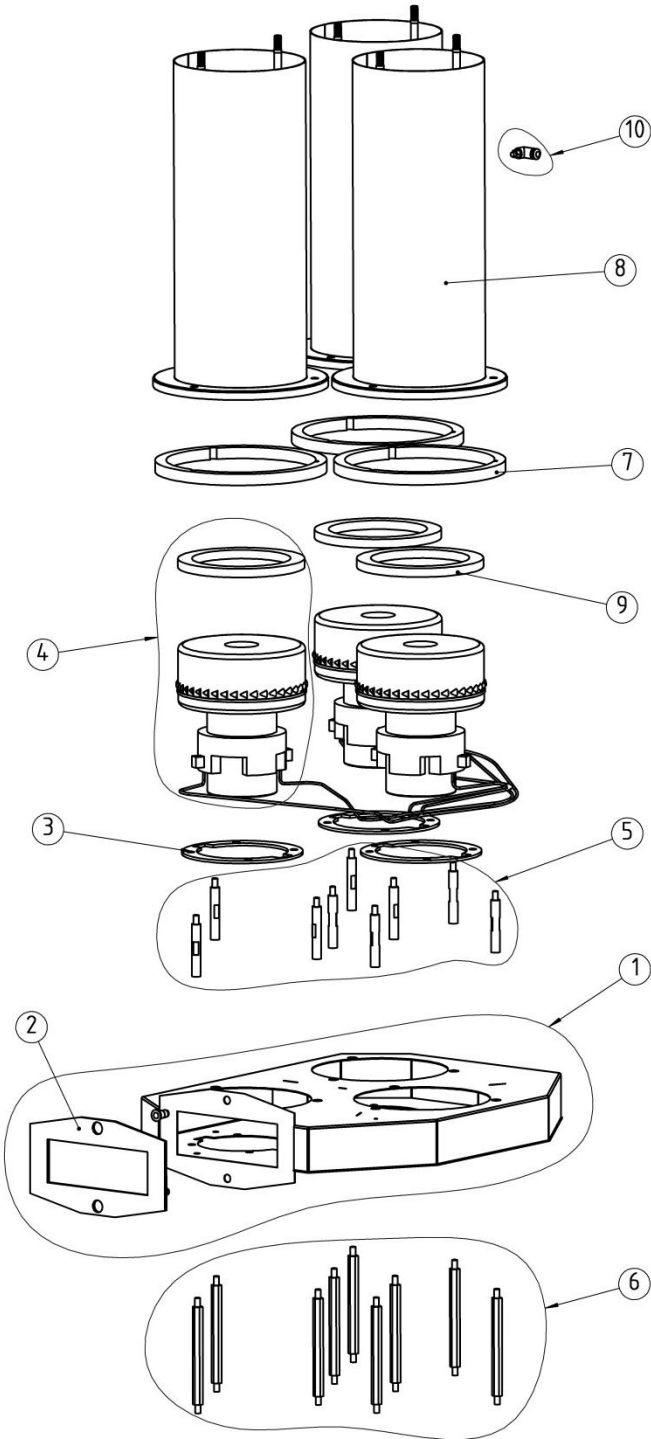

<b>POS.</b>	<b>QTY.</b>	<b>NUMBER</b>	<b>DESCRIPTION</b>
<b>1</b>	<b>1</b>	<b>201100171</b>	<b>MOTOR BOX (ex. S36)</b>
<b>2</b>	<b>1</b>	<b>201100172</b>	<b>SEALING 160 mm OUTLET</b>
<b>3</b>	<b>1</b>	<b>201100173</b>	<b>SEALING PACKING</b>
<b>4</b>	<b>3</b>	<b>200800060e</b>	<b>MOTOR 120V 800W KIT</b>
<b>5</b>	<b>1</b>	<b>201100174</b>	<b>UPPER SUPPORT PIN KIT (ex. S36)</b>
<b>6</b>	<b>1</b>	<b>201100175</b>	<b>LOWER SUPPORT PIN KIT (ex. S36)</b>
<b>7</b>	<b>1</b>	<b>201100170</b>	<b>TOP MOTOR SEALING</b>
<b>8</b>	<b>3</b>	<b>201100176</b>	<b>FILTER HOUSING</b>
<b>9</b>	<b>1</b>	<b>201100177</b>	<b>MOTOR SEALING KIT</b>
<b>10</b>	<b>1</b>	<b>201000178</b>	<b>NIPPLE ANGLE KIT</b>



# S36 120V

MOTOR COVER

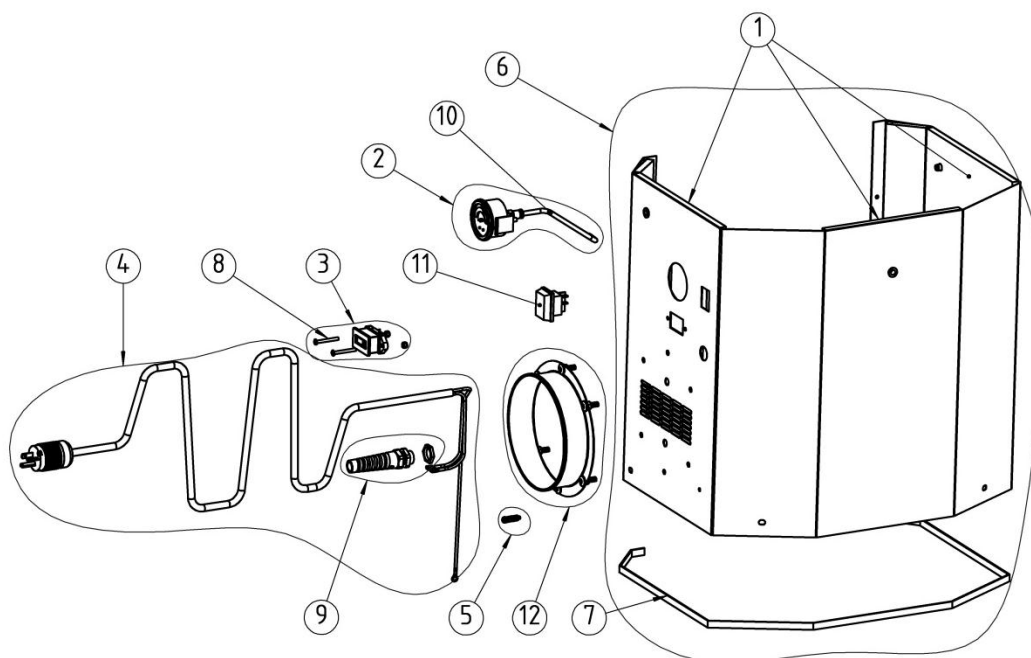

POS.	QTY.	NUMBER	DESCRIPTION
1	1	201100165a	AC FOAM ETL VERSION
2	1	200700413	MANOMETER KIT
3	1	201000133	COUNTER SET
4	1	201500177	CORD SET PACKING (NEMA 5-20P)
5	1	201000211	GROUNDING SCREW KIT
6	1	201000212e	MOTOR COVER 120V KIT
7	1	201100163	SEALING PACKING
8	2	201000213	SCREW SET OF COUNTER
9	1	201100150	CABLE FIX KIT (PG13)
10	1	201100164	HOSE PACKING
11	1	201100151	SWITCH PACKING
12	1	201000208	160MM EXHAUST AIR OUTLET PACKING

# ACCESSORIES S36

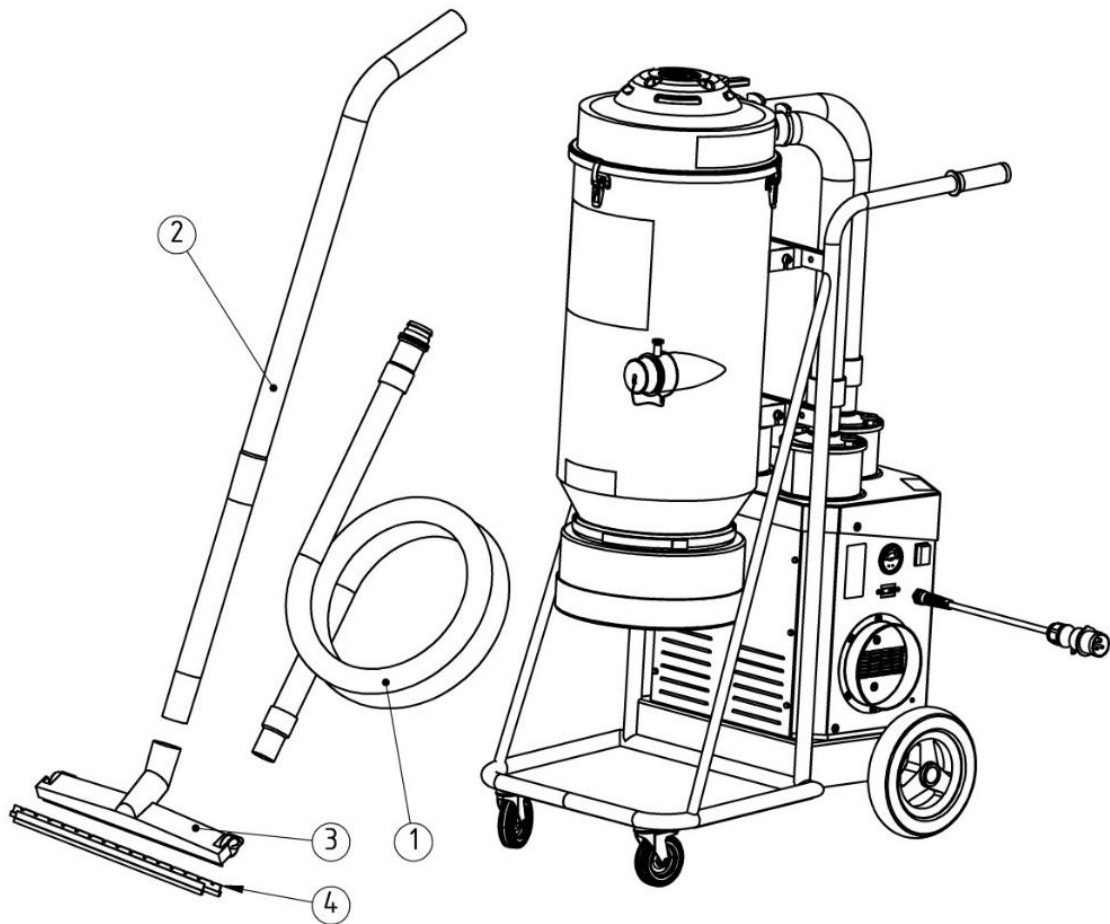

POS.	QTY	NUMBER	DESCRIPTION
1	1	201000128	HOSE 63mm x 10m (ex. S36)
(1)	1	201000061	HOSE 51mm x 7,5m (ex. S26)
2	1	1224035	50S Wand Kit (2pc) dia 50
3	1	1326087	S450 Floor Tool 50mm x 450mm
4	1	1340005	AG46A BRUSHES (L=400/445)





*Clean air from Sweden*



Pullman Ermator Inc.	Pullman Ermator AB
Phone: 855-736-2869	Phone: +46(0)240660960
Fax: 813-685-6782	Fax: +46(0)240663060
Address: 10702 N. 46th street - Tampa, FL 33617, USA	Address: Industrivägen 10, 77734, Sweden
E-mail: <a href="mailto:orders@ermatorusa.com">orders@ermatorusa.com</a>	E-mail: <a href="mailto:info@pullman-ermator.se">info@pullman-ermator.se</a>