

FÖRST[™]

ST6 Woodchipper

USER MANUAL

ENGLISH

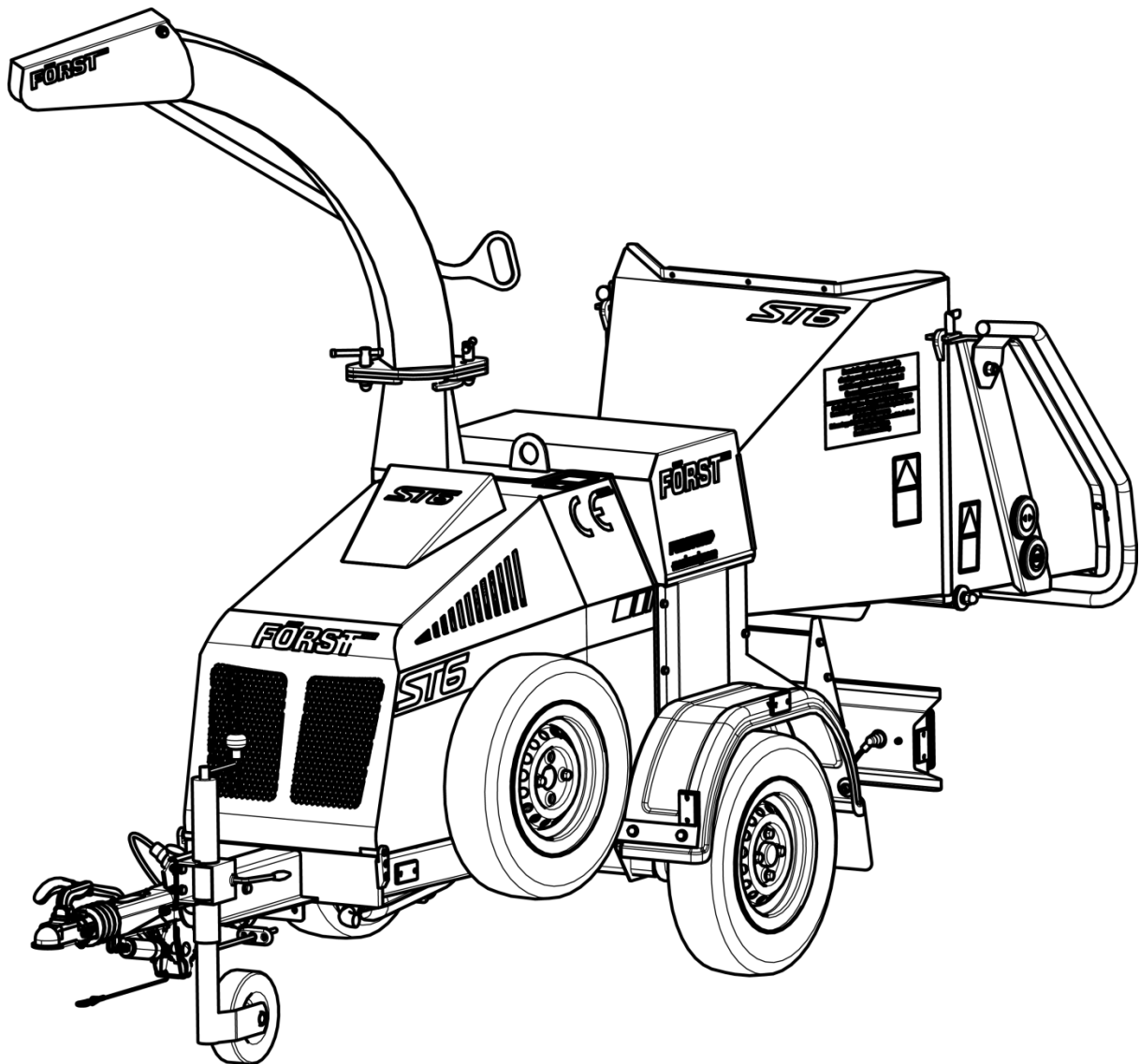

3/12/2015 Revision 13

Redwood Global Ltd,
Unit 86, Livingstone Road, Walworth Business Park, Andover,
Hampshire. SP10 5NS. United Kingdom

Table of Contents

Introduction.....	3
Purpose of machine.....	4
Exterior component identification.....	5
Safety	7
Safe working	7
Machine lifting.....	8
DOs and DON'Ts	9
Noise test information.....	10
Machine operation.....	11
Machine control panel, start/stop & operating settings	12
Ignition switch	12
Feed speed adjustment.....	14
Feed jam & blockages.....	15
Transportation.....	16
Attaching to the vehicle tow hitch	17
Unhitching the machine.....	17
Routine maintenance.....	18
Debris screen.....	19
Engine maintenance	19
Fastener tightening torques.....	19
Service schedule	20
Covers: engine, chipping chamber, side panels.....	22
Engine bay	23
Blade sharpening	25
Hydraulic oil filter	26
Drive belt tension.....	28
Battery.....	29
Battery safety information	29
Storage and transport.....	29
Initial operation	29
Battery removal & maintenance.....	29
Charging	30
Jump starting.....	30
Taking battery out of service	31
Parts lists	32

Hopper tray touch sensor 12-A-020	32
Chipping chamber assembly 12-A-005.....	33
Chipping chamber assembly 12-A-005. Bottom feed.....	33
Chipping chamber assembly 12-A-005. Bottom feed & anvil.....	35
Chipping chamber assembly 12-A-005. Drive	36
Chipping chamber assembly 12-A-005. Flywheel drive.....	37
Chipping chamber assembly 12-A-005. Bottom feed roller cover.....	38
Chute assembly 12-A-007	39
Top feed roller assembly 12-A-008	40
Flywheel assembly 12-A-010	41
Flywheel belt tensioner assembly 12-A-012	42
Fuel tank assembly 12-A-026.....	43
Hydraulic pump assembly 12-A-022	44
Light board assembly 12-A-024	45
Running gear – hitch & axle	46
Hydraulics circuit diagram.....	46
Electrical circuit diagram – Mechanical & touch sensor hopper	47
Decals	48
Manufacturer’s Statutory Plate.....	49
Warranty	50
CE Certificate.....	51

Introduction

Thank you for becoming the owner of this Redwood Global Ltd, Forst ST6 woodchipping machine. By observing the contents of this manual, we hope the machine gives safe and productive service. This user manual is intended for the owner/operator to safely and effectively operate this machine and carry out routine maintenance between services. This is not a comprehensive service manual. See Service Schedule for routine maintenance and when to take the machine to a service specialist. For engine maintenance, please refer to the engine manual supplied with this machine.

This machine has been through a pre-delivery inspection before leaving the factory and is ready to use.

Before use and as a minimum, the safety and machine operation sections covered on pages 4 to 13 must be read and understood.

Failure to do so could result in serious injury or loss of life to the operator and others nearby. Also, damage to property and this machine may occur. Please observe and obey all warning signs (decals) located on the machine. Their meaning is covered in this manual under decals.

All personnel working with this machine must be adequately trained in its use and most importantly, follow the advice on safe working practices.

Redwood Global Ltd endeavour to continuously develop and improve its products. They reserve the right to make changes at any time, without notice or incurring any obligation.

Continuous improvement will affect machine design and production so there may be minor discrepancies between the actual product and this manual.

This manual must remain with the machine for reference by operators and includes hiring or if the machine is resold.

Purpose of machine

The Forst ST6 is designed to reduce wood material up to 150mm diameter to woodchip. This machine is capable of processing up to 5 tonnes of wood per hour.

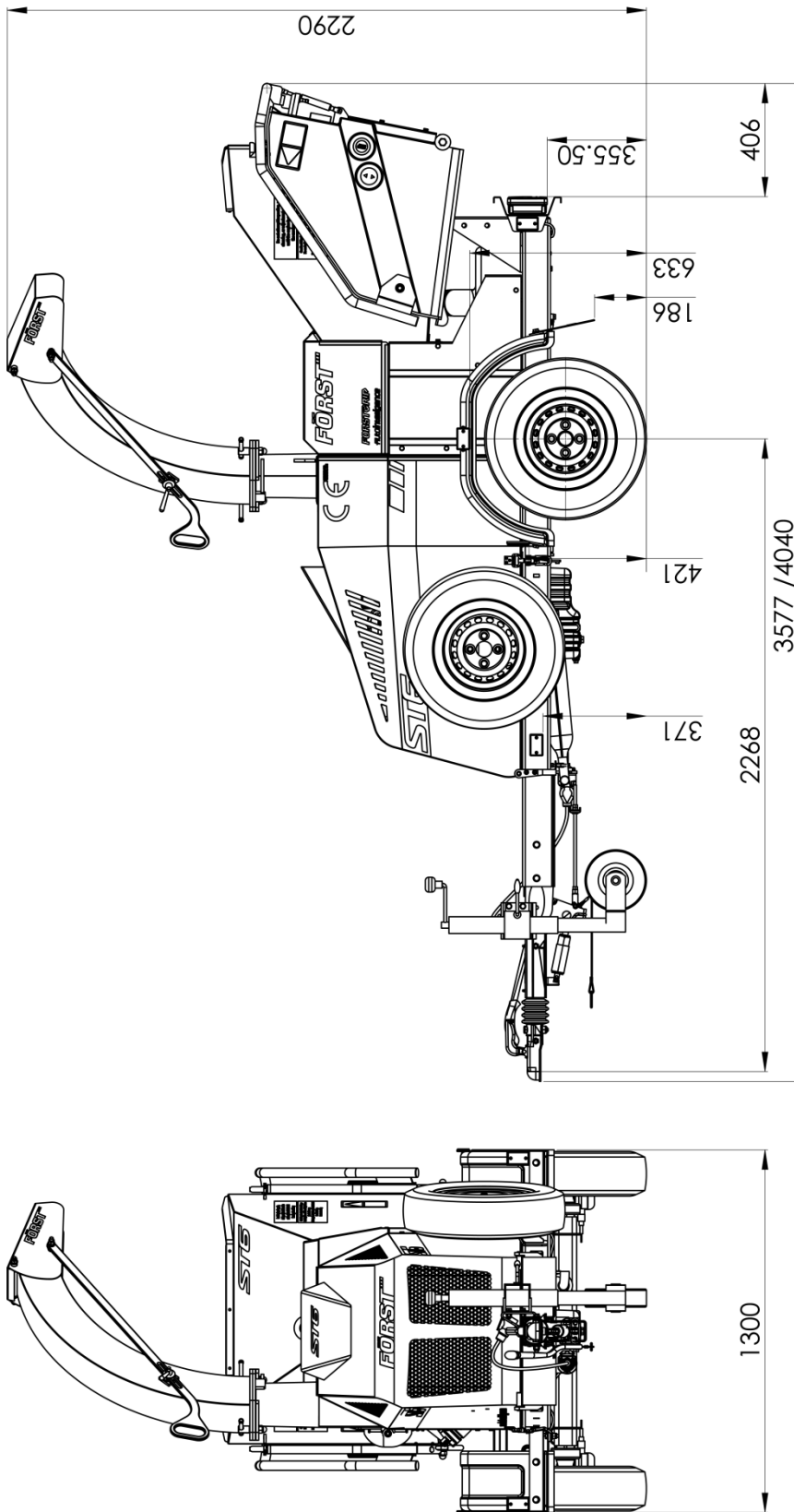

Engine size	Kubota 4 cyl diesel	Roller feed	Twin series hydraulic motors
Maximum power	26.1 kW (35hp)	Maximum material diameter	150mm
Cooling method	Water cooled	Fuel capacity	30 litres
Overall weight	955kg	Hydraulic oil capacity	20 litres
Starting method	Electric	Material processing capacity	5 Tonnes/Hr
		Fuel type	Diesel

Exterior component identification

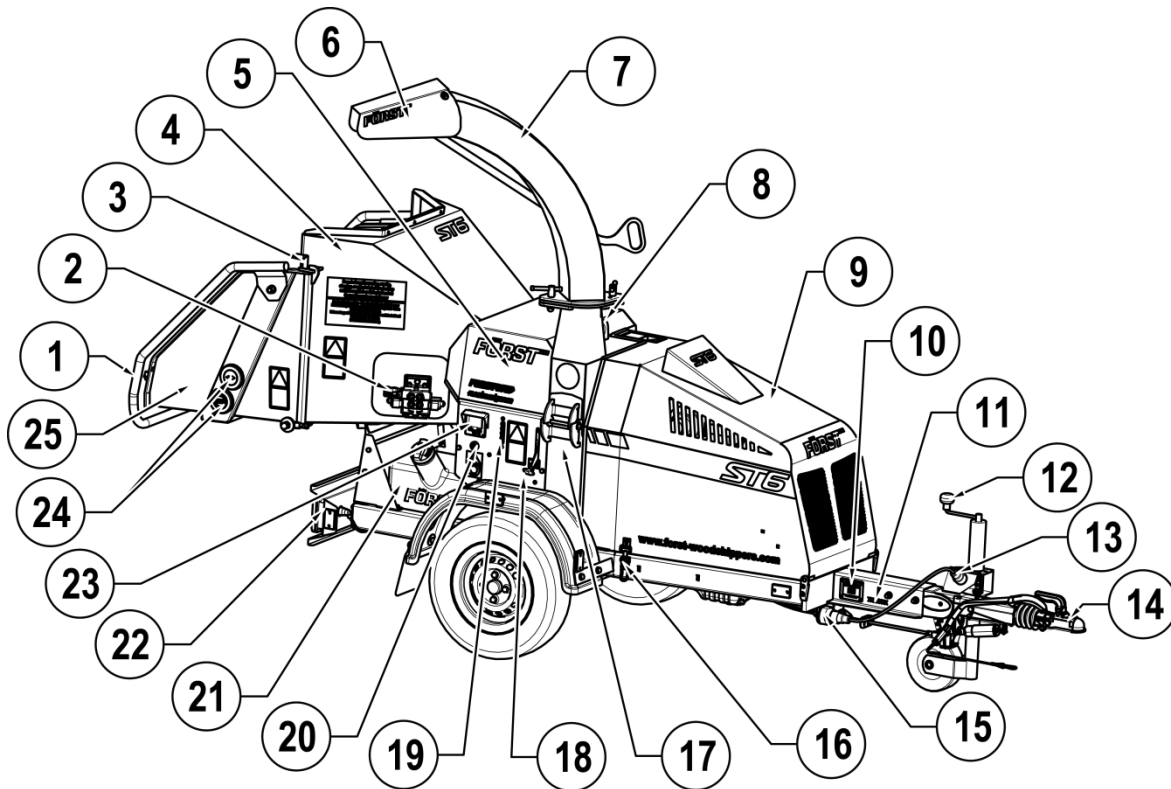
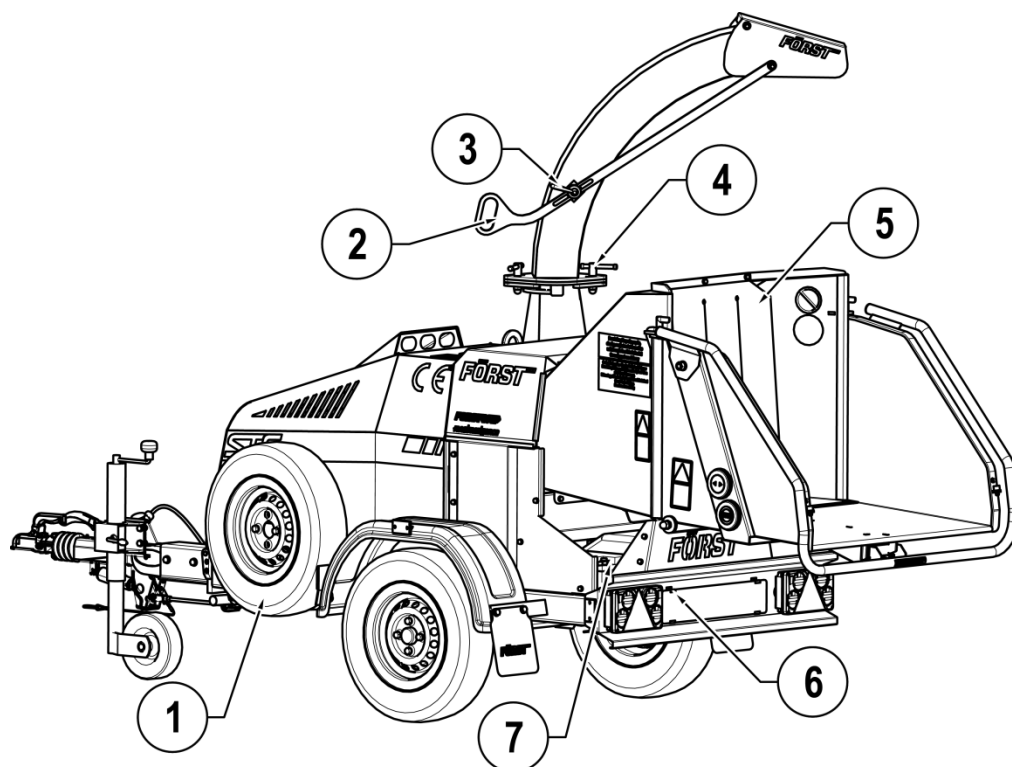

Figure 1

1	TRIP BAR
2	CONTROL VALVE FEED SPEED ADJUSTMENT
3	HOPPER TRAY LATCH
4	HOPPER
5	CHIPPING CHAMBER COVER
6	CHUTE HOOD
7	CHUTE
8	MACHINE LIFTING EYE
9	ENGINE COVER
10	MANUFACTURER'S STATUTORY PLATE
11	SERIAL NUMBER
12	JOCKEY WHEEL HANDLE
13	VEHICLE CONNECTION LEAD
14	TOW HEAD
15	MACHINE LIGHT BOARD SOCKET
16	ENGINE COVER LATCH
17	CHIPPING CHAMBER
18	THROTTLE
19	GREASE POINT
20	IGNITION SWITCH
21	FUEL TANK
22	LIGHT BOARD
23	CONTROL PANEL
24	FEED START/STOP TOUCH SENSORS
25	HOPPER TRAY

**Figure 2**

1	SPARE WHEEL
2	CHUTE HANDLE
3	CHUTE HOOD LOCK HANDLE
4	CHUTE ROTATION LOCK HANDLE
5	SAFETY CURTAIN
6	REMOVEABLE NUMBER PLATE HOLDER
7	BATTERY

Safety

Safe working

Before using this machine, make sure that you are trained and fluent in its operation. Know the location of and how to use all the safety features. Know how to control the feed and stop the machine in an emergency. Be familiar with the hazards and safe working practices to prevent injury and damage to property and machine. Also be aware of the legal restrictions for personnel and towing with vehicles.

1. The minimum age for service personnel is 18 years. Personnel aged 16 can use the machine for training under supervision by a suitably trained person of 18 years or over.
2. Operators and personnel working with this machine must not be under the influence of alcohol, drugs or medication that would impair judgement, concentration or reaction times. Excessive tiredness is also a risk.
3. In use, woodchip and debris are ejected with considerable force from the chute and can travel up to 10m. Make sure the chute directs woodchip to a safe location so that no one can be harmed or property damaged. Do not allow discharge to be directed onto roads or public rights of way.
4. Maintain a 10m exclusion zone around the machine and clearly mark if in a public area. Keep this area free of material build up.
5. Make sure the machine is on even, level and stable ground and cannot move or topple when in use. Use wheel chocks if necessary.
6. Keep children and animals well away from the working area.
7. The machine operator must wear protective equipment:
 - a. Chainsaw safety helmet with mesh visor.
 - b. Correctly rated ear defenders.
 - c. Work gloves with elasticated wrist bands.
 - d. Steel toe cap boots.
 - e. Close fitting heavy duty non-snap clothing.
 - f. Protect breathing with a face mask if appropriate. Some plant material can give off harmful dust and poisonous vapours. This may cause respiratory problems or serious poisoning. Check the material to be processed before starting.
 - g. **DO NOT** wear rings, bracelets, watches, jewellery or anything that could be caught on the material being fed and draw you into the machine.
8. All personnel operating or feeding material into the machine must wear heavy duty non-snap clothing to help prevent being caught on material and drawn into the machine. The feed mechanism of this machine uses high powered hydraulic motors to drive sharp toothed rollers that feed material into the cutting blades. **DO NOT** take risks with it. **NEVER ASSIST ANY MATERIAL INTO THE FEED ROLLERS WITH HANDS OR FEET.** Use a push stick or further long material if necessary.
9. Never climb onto the hopper area while the machine is in operation.
10. Material can be forcibly ejected from the hopper towards the operator. Ensure full head and face protection is worn.

11. Very twisted material should be trimmed into manageable pieces. Failure to do this can result in material extending outside the hopper, moving aggressively side-to-side creating a hazard to the operator.
12. Do not try to force material over 150mm in diameter into the machine.
13. Carefully site the machine so operators can work furthest from any local danger. For example, on a road side, place machine so operators work on the verge and not in the road exposed to traffic.

Machine lifting

The lifting eye is designed for securely holding the machine's weight only. Do not use hoist hook directly on the lifting eye. Use a correctly rated safety shackle. Inspect lifting eye before each use and do not use if damaged.

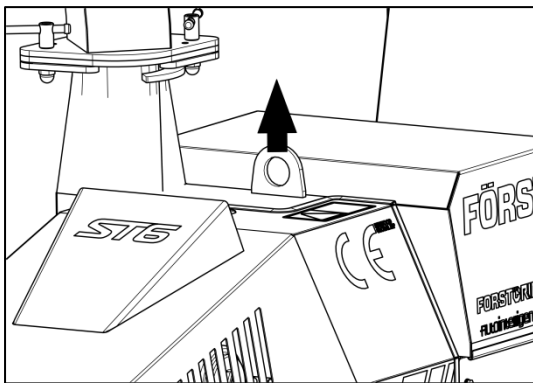

Figure 3

DOs and DON'Ts



DO stop the machine before making any adjustments, refuelling or cleaning.

DO make sure the machine has stopped rotating and remove the ignition key before any maintenance or the machine is left unattended.

DO ensure that the machine is level, well supported and cannot move during use.

DO run the machine at full throttle.

DO conduct regular machine checks for visual fluid leaks.

DO take regular breaks. Wearing protective equipment can be hot and tiring leading to a lack of concentration, increasing the risk of having an accident.

DO keep hands, feet and clothing out of feed area, chute and moving parts.

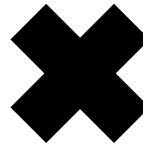

DO NOT use machine in poor visibility or insufficient light to see clearly.

DO NOT use or attempt to start the machine without the discharge chute or guards correctly and securely fitted.

DO NOT stand in front of the chute.

DO NOT allow the following to enter the machine as damage is likely:

BRICKS	METAL
STRING	GLASS
CLOTH	RUBBER
PLASTIC	ROOTS
STONES	BEDDING PLANTS

DO NOT smoke when refuelling. Diesel fuel is highly flammable and explosive in certain conditions.

DO NOT let anyone who has not received instruction, operate the machine.

DO NOT climb on the machine at any time except for a tracked machine ride-on plate where fitted.

DO NOT handle material partially engaged in the machine while in operation.

DO NOT touch any exposed wiring while the machine is running.

Noise test information

Machine	Forst ST6
Notes	Tested chipping 50 x 50mm sawn pine 4.2m in length.

Noise levels above 85dB (A) will be experienced at the working position and within a 4 metre radius. Operators and personnel within a 4 metre radius must wear appropriate ear protection at all times while machine is in operation to prevent the risk of hearing damage.

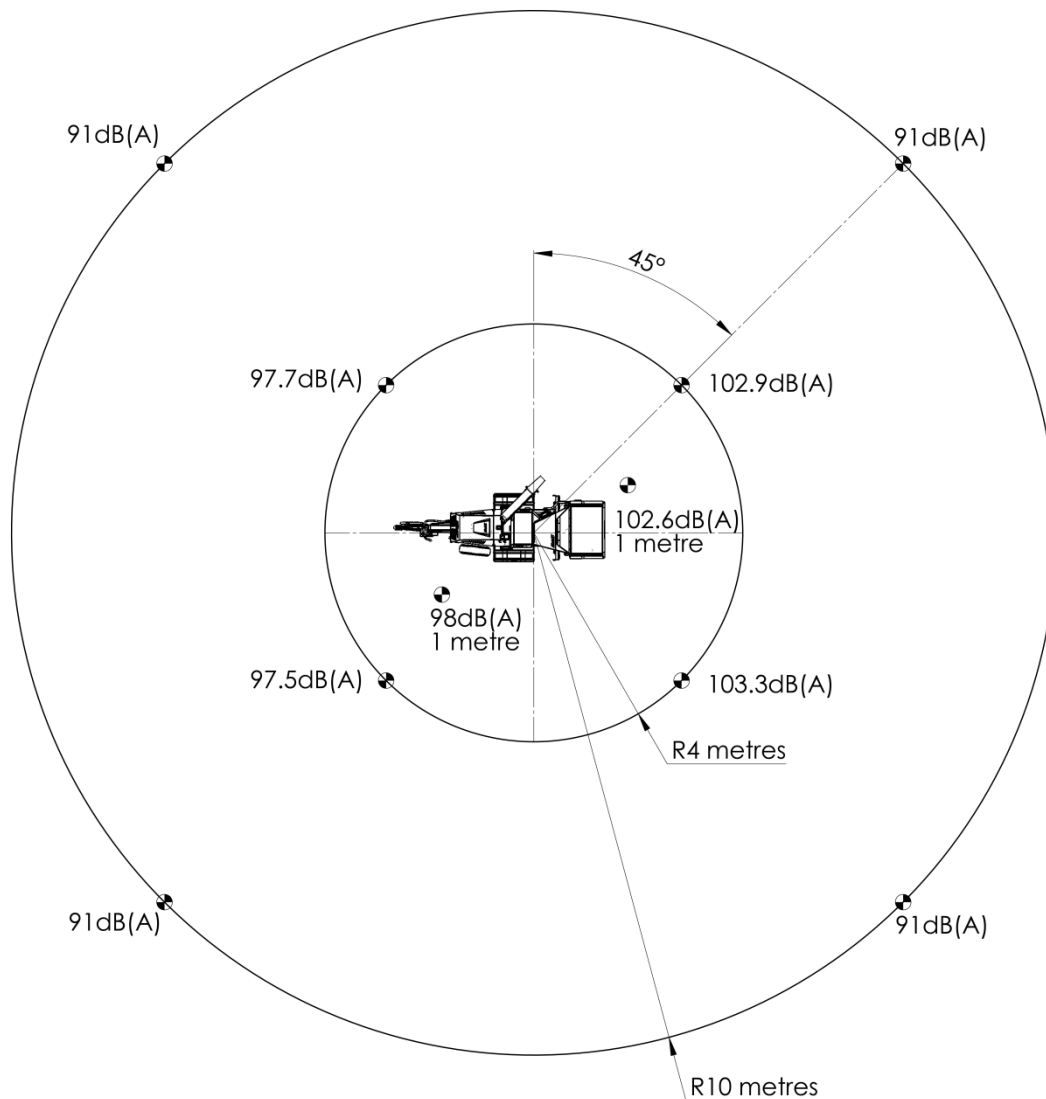

A-weighted emission sound pressure (beside operator's ear) $L_{pA} = 111.7\text{dB(A)}$.
 Peak C-weighted instantaneous sound pressure (beside operator's ear) $LC_{peak} = 136.7\text{dB(C)}$. Results at 10 metre radius are calculated.

Guaranteed sound power: 122dB(A)

As required by Machinery Directive 2006/42/EC "Noise Emission in the environment by equipment for use outdoors."

Machine operation

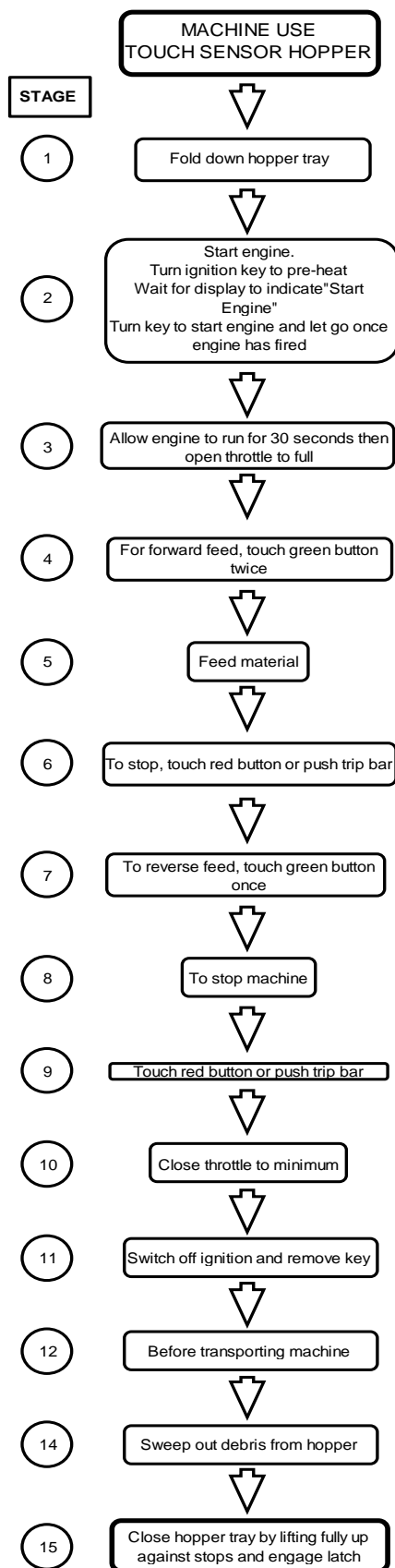

Machine control panel, start/stop & operating settings

This machine is fitted with an engine PLC (Programmable Logic Controller) system that manages the engine, feed and all safety features. The control panel is located on the right side panel (see Figure 1). Feed and engine speed are controlled with a "No Stress" function ensuring that cutting conditions are kept within optimum limits. This maximises throughput while minimising jams and blockages. There will be times when material is being cut and the feed will momentarily stop until engine speed increases. At this point, the feed will start without warning. Service warnings shown below will be displayed at certain intervals. The engine will not start until OK is pressed.

First 20 Hour Warning: "Change Hydraulic Oil Filter"

Every 20 Hour Warning: "Blade and Machine check required see manual"

50 Hour Service Warning: "1st Full Service recommended"

Every 200 Hour Service Warning: "Full Service recommended"

Using the control panel:

Ignition switch

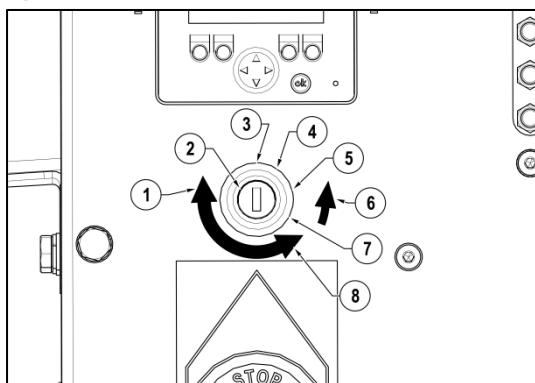

1	KEY ROTATION IN SWITCH TO START
2	IGNITION SWITCH POSITIONS & FUNCTION
3	OFF
4	IGNITION
5	PRE-HEAT
6	SWITCH SPRING BIASED TO PRE-HEAT WHEN RELEASED
7	START
8	KEY ROTATION IN SWITCH TO STOP

Figure 4

Turn ignition key clockwise to first position, then to pre-heat (see Figure 4), start display will show, enables pre-heat automatically showing start display + pre-heat.



OR with Pre-heat

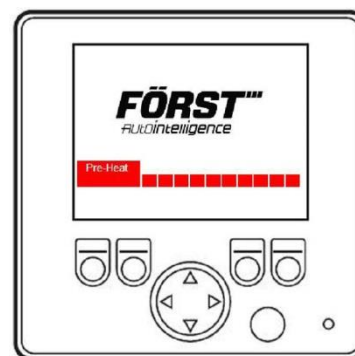

Turn ignition key fully clockwise to crank engine. Display will automatically go to P1



If engine fails to start, turn key to off position and start process again. P1 shows Working Hours and charging indicator text at the screen bottom centre.

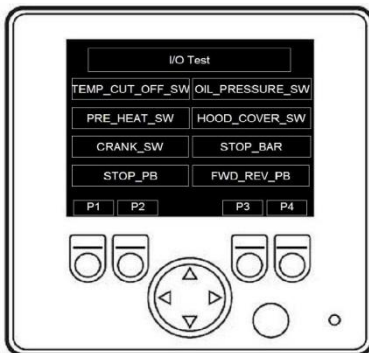

P2 shows I/O tests. Tests all functions and safety controls.

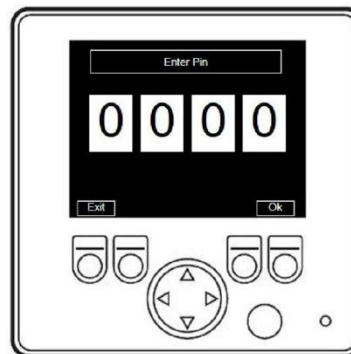
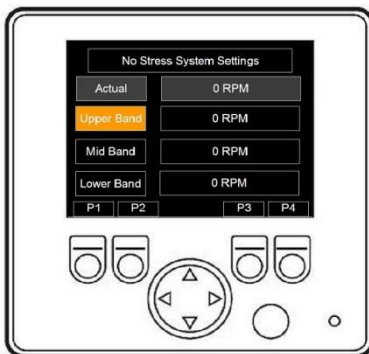

Pin screen

P3 shows No-Stress Settings

Actual RPM

Upper Band - 1400 RPM

Mid Band – 1125 RPM

Lower Band – 925 RPM

Pin screen automatically displays if any setting changes are attempted.

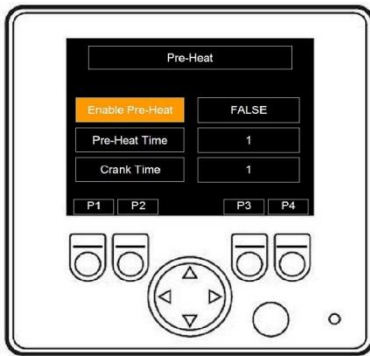

P4 shows Pre-Heat Settings

Enable Pre-Heat – True

Pre-Heat Time – 10

Crank Time – 3

To stop engine turn off with ignition key by turning fully anti-clockwise.

Feed speed adjustment

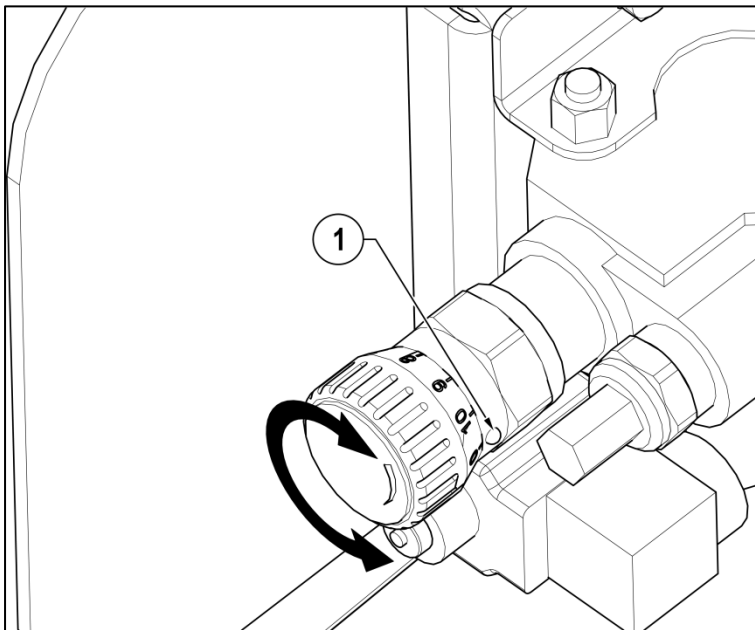

1 CONTROL VALVE FEED SPEED ADJUSTMENT. POSITION INDICATED BY PIP. 0 = MINIMUM 10 = MAXIMUM

Figure 5

The feed speed can be adjusted to suit the material being chipped see Figure 5. Turn dial to align number with pip. Set feed speed so that the No-Stress operates as little as possible, this will give the highest throughput. When feeding Leylandii or leafy material, set feed roller speed to 4.5.

Feed jam & blockages

Be aware that whatever is fed into the machine has to come out of the chute. Always monitor the state of chip flow out of the chute. If this stops, **STOP FEEDING MATERIAL IMMEDIATELY**. Continuing to feed material will further compact a blockage and make it more difficult to clear.

If the chipping chamber or chute become blocked:

1. Stop the engine and remove ignition key.
2. Remove chute and check that it is clear.
3. If the chipping chamber is blocked, open the engine cover, then chipping chamber cover. **DO NOT REACH INTO THE CHIPPING CHAMBER WITH HANDS**. Beware that the flywheel within the chipping chamber has two sharp blades mounted on it and can move causing a serious injury risk. Wearing protective gloves and using a piece of wood, carefully clean out the chipping chamber.

If feed becomes jammed (see Figure 6):

1. Stop the engine and remove ignition key.
2. Open engine and chipping chamber covers.
3. Release feed roller spring tension on both sides by slackening off the eye bolt nuts and remove if necessary.
4. Insert feed lift tool and lift top feed roller to fully open.
5. Insert M12 screw into side of feed chamber and screw completely in. Lower top feed roller onto the screw to secure in the open position.
6. There should now be access to the feed chamber. Beware that this is the machines cutting zone. The top and bottom feed rollers have sharp teeth and the flywheel cutting blades are not far from them. **DO NOT PUT HANDS INTO THIS AREA**. Wearing protective gloves and using a piece of wood, carefully clear jammed material inside feed chamber.
7. When clear, lift top feed roller via lifting tool, remove top feed M12 securing screw, lower top feed roller and remove lifting tool.
8. Re-assemble feed tensioner springs and replace covers.

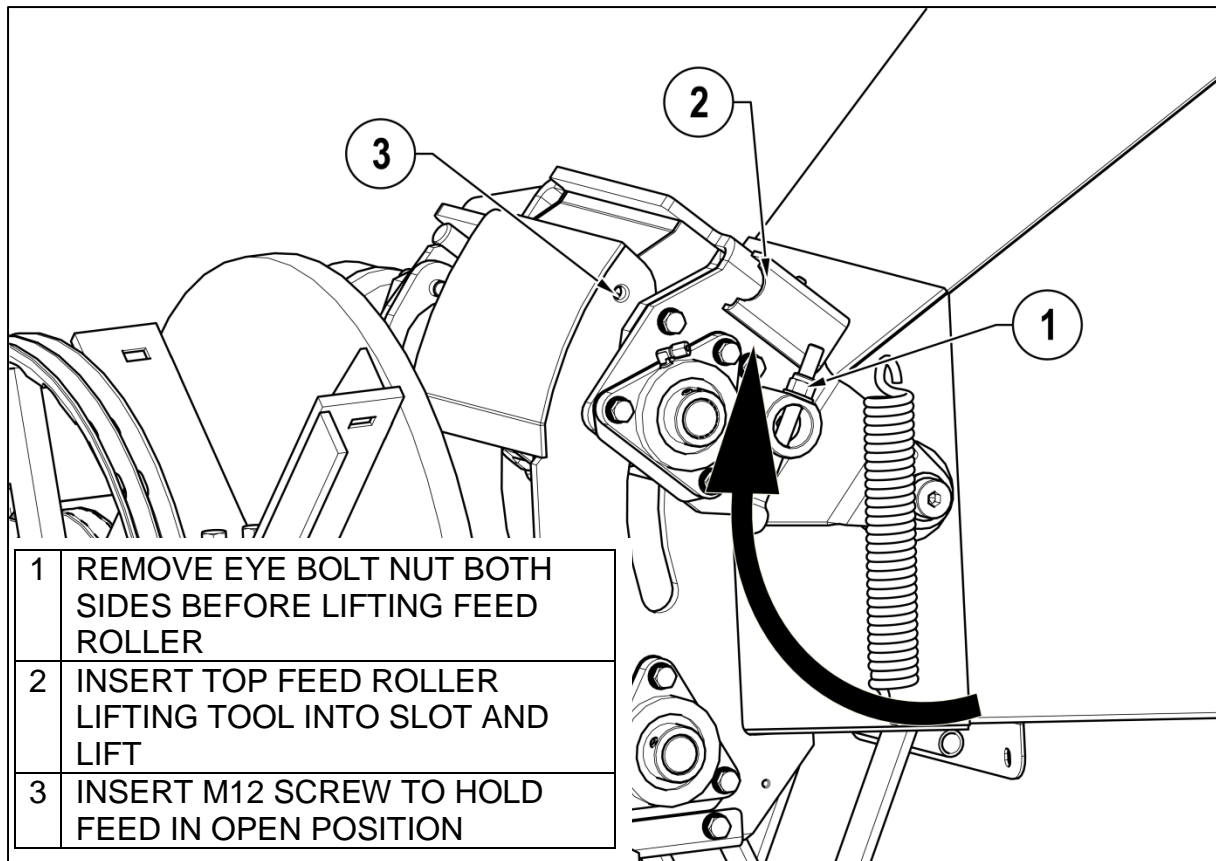

Figure 6

Transportation

- When towing the machine the maximum legal speed limit is 60mph.
- On very rough and uneven road surfaces, reduce speed to protect the machine from undue vibration.
- When off road, avoid objects that may collide with the machine underside.
- Avoid steep gradients when off road.
- Avoid excessively pot holed ground.
- Exercise caution when reversing the machine as the short wheel base will react quickly to steering.
- Keep tyre pressures inflated to 3.8 Bar or 55 psi.
- Check wheel nuts are tightened to between 90Nm and 100Nm.
- Clear machine of loose woodchip material before departing.
- Ensure the chute is securely fixed at the inboard position before departing.
- Ensure that the hopper tray is closed in the up position and the locking latch is fully engaged before departing.

Attaching to the vehicle tow hitch

- Check that the vehicle ball hitch is well greased.
- Raise the machine hitch by turning the jockey wheel handle anticlockwise until the hitch socket is above the vehicle hitch ball.
- Reverse the vehicle until the ball is directly below the machine hitch socket.
- Attach the breakaway cable/secondary coupling to a suitably strong point on the vehicle, not the ball hitch.
- Ensure the barrel lock is retracted from the tow head.
- Grasp handle on tow head and push back catch with thumb.
- Wind the jockey wheel handle clockwise to lower the hitch socket onto the ball hitch.
- Release tow head handle and continue to wind the jockey wheel handle clockwise. The tow head should snap into place on the ball hitch. If it doesn't, repeat previous two steps.
- Wind jockey wheel up until fully retracted and the jockey wheel frame is seated in its notch on the stem. The machine's weight should be fully on the vehicle.
- Release the jockey wheel clamp and slide the jockey wheel assembly fully up then tighten clamp.
- Connect the vehicle trailer socket to the machine socket with the connection lead. Check all machine lights and tow vehicle lights are working correctly.
- Insert the barrel lock for security.
- The machine is now properly attached to the tow vehicle.

Unhitching the machine

- Ensure the machine will not roll away after being disconnected from the tow vehicle.
- Disconnect the trailer socket from the tow vehicle.
- Release the barrel lock.
- Release the breakaway cable/secondary coupling.
- Release the jockey wheel assembly clamp, fully lower the wheel and tighten the clamp.
- Wind the jockey wheel handle anticlockwise until it starts to take the machine weight.
- Grasp the tow head handle and release the catch with your thumb.
- Wind the jockey wheel handle anticlockwise until the tow head is clear of the ball hitch.
- Drive the tow vehicle clear of the machine.
- Level the machine by winding the jockey wheel handle.
- The machine is now fully detached from the tow vehicle.

Routine maintenance

The following must be checked at least on a daily basis during use (also see Service schedule):

- Check engine oil. See Figure 11
- Check water level in radiator reservoir bottle. See Figure 11
- Check debris screen on front of radiator and remove any debris (see Figure 7).
- Check hydraulic oil level. When the machine is new, the oil level may drop during initial use. Regularly check and top-up until level settles. If a top up is required, thoroughly clean around filler cap before removing to help prevent debris falling into oil tank, top up as required and replace filler cap. See Figure 12
- Grease machine. Every 8 hours, one pump of grease to each of the four nipples at the central grease point manifold located near the control panel. See Figure 1.
- Check all fasteners are present and assembled to the correct torque.
- Check proximity sensors on engine cover, removable hopper and trip bar are not damaged and working correctly. The trip bar sensor is the most vulnerable and if severely damaged could result in the trip bar not working.
- Check drive belt tension and adjust as necessary. See Figure 12, Figure 13 & Figure 17.
- Check pulleys and taper lock on flywheel shaft. See Figure 13.
- Check flywheel blades for damage and sharpness. Machine performance is adversely affected if blades are blunt or damaged. Replace and sharpen blades as required. Make sure that the blade seat is clean and free of damage before reassembly. Shims are available to adjust for blade size reduction after sharpening. Please refer to blade sharpening for size limits, adjustment shims and setting. Ensure blade fasteners are correctly installed and tightened to the appropriate torque. Check after 1 hours' work then weekly.
- Anvil and side anvil are replaceable and double sided. Make sure that the anvil seat is clean and free of damage before reassembly.
- Exercise extreme care to avoid injury when removing and replacing blades and anvils. The flywheel can turn creating crush and cutting points in and around the chipping chamber.
- Check all hydraulic hoses and fittings after 5 hours' work. Beware of hydraulic oil leaks, they can cause serious injury while the engine is running and the system is under pressure. A leak can easily inject high pressure oil deep into flesh and blood stream requiring immediate medical attention. **DO NOT CHECK FOR LEAKS WHILE THE ENGINE IS RUNNING.** Hoses to the feed roller hydraulic motors are the most likely to become damaged as they are

constantly moving during use. If hoses are replaced, all seals must be replaced at the same time.

- Check top and bottom feed motor bracket bolts weekly.

Debris screen

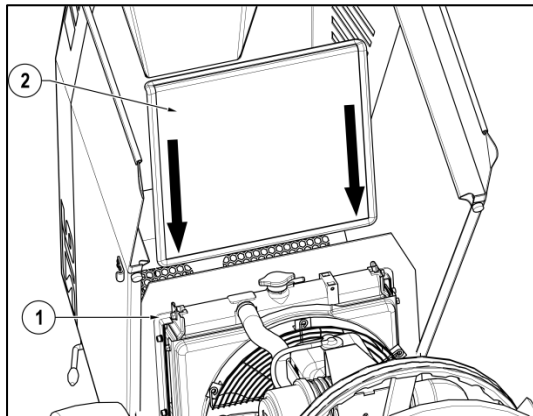

1	LOCATION SLOTS IN FRONT OF RADIATOR
2	DEBRIS SCREEN

Figure 7

Engine maintenance

Please refer to the engine manual supplied with this machine for the following:

- Checking the engine oil.
- Changing the engine oil, oil filter and fuel filter.

Fastener tightening torques

Tightening torques for class 8.8 and 10.9 fasteners				
	Class 8.8		Class 10.9	
	Nominal torque Nm	Max/Min torque	Nominal torque Nm	Max/Min torque
Size				
M6	10	9.5/10.4	14.5	14/15.3
M8	25	23.1/25.3	35	34/37.2
M10	49	46/51	72	68/75
M12	86	80/87	125	117/128
M12x1.5 wheel screws	95	90/100		
M16	210	194/214	310	285/314
M20	410	392/431	610	558/615
M24	710	675/743	1050	961/1059

All machine fastener torques should be regularly checked to the above table. In particular, those for the flywheel blades, flywheel bearings, axle assembly, hitch, road wheels and engine mounts.

Covers: engine, chipping chamber, side panels

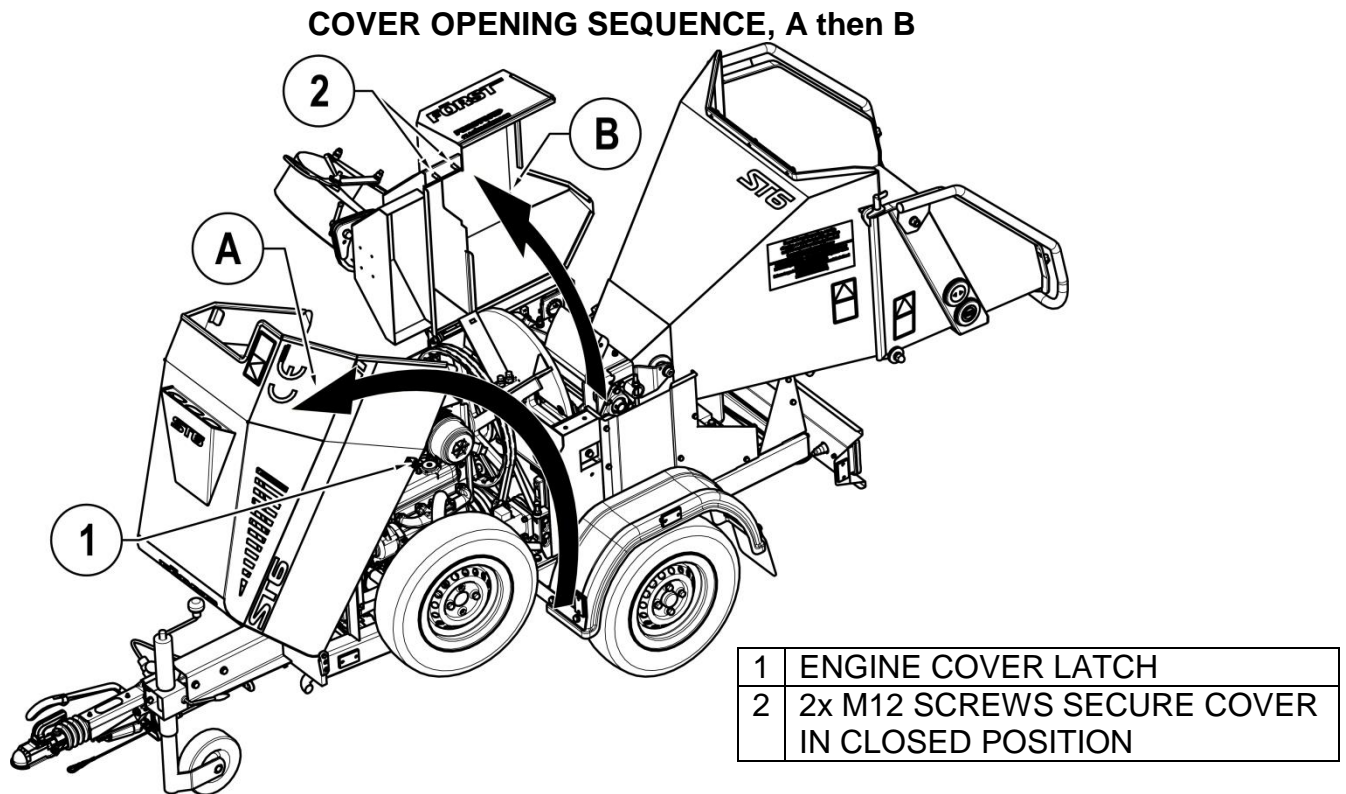

Figure 8

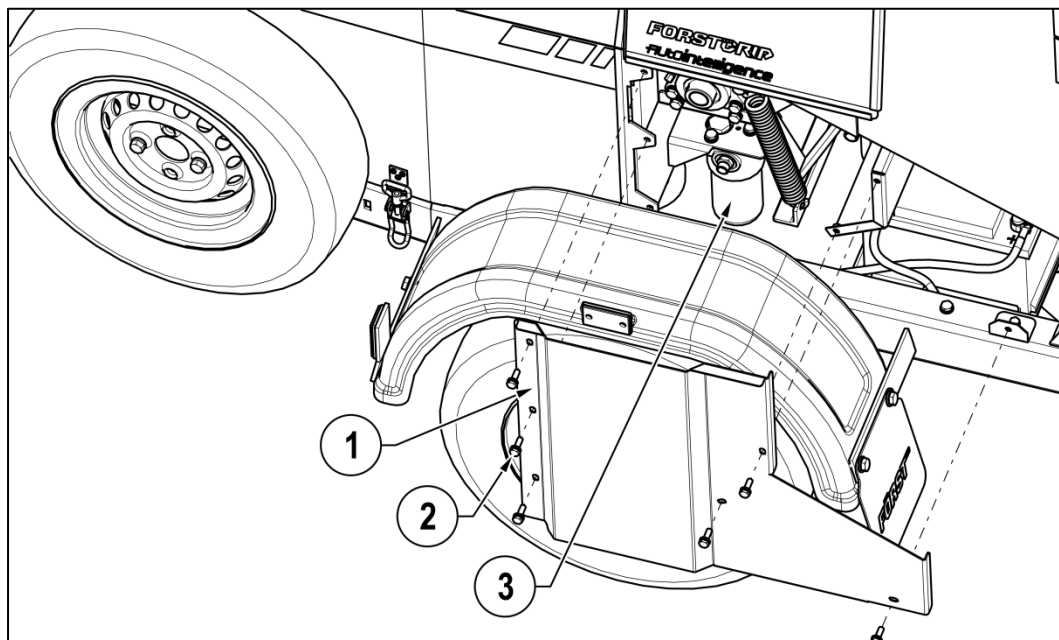

Figure 9

1	LEFT SIDE PANEL CAN BE REMOVED FOR ACCESS TO FEED ROLLER TENSION SPRING ANCHORS. OPPOSITE SIDE PANEL CAN ALSO BE REMOVED
2	6x FASTENERS
3	HYDRAULIC OIL FILTER HOUSING

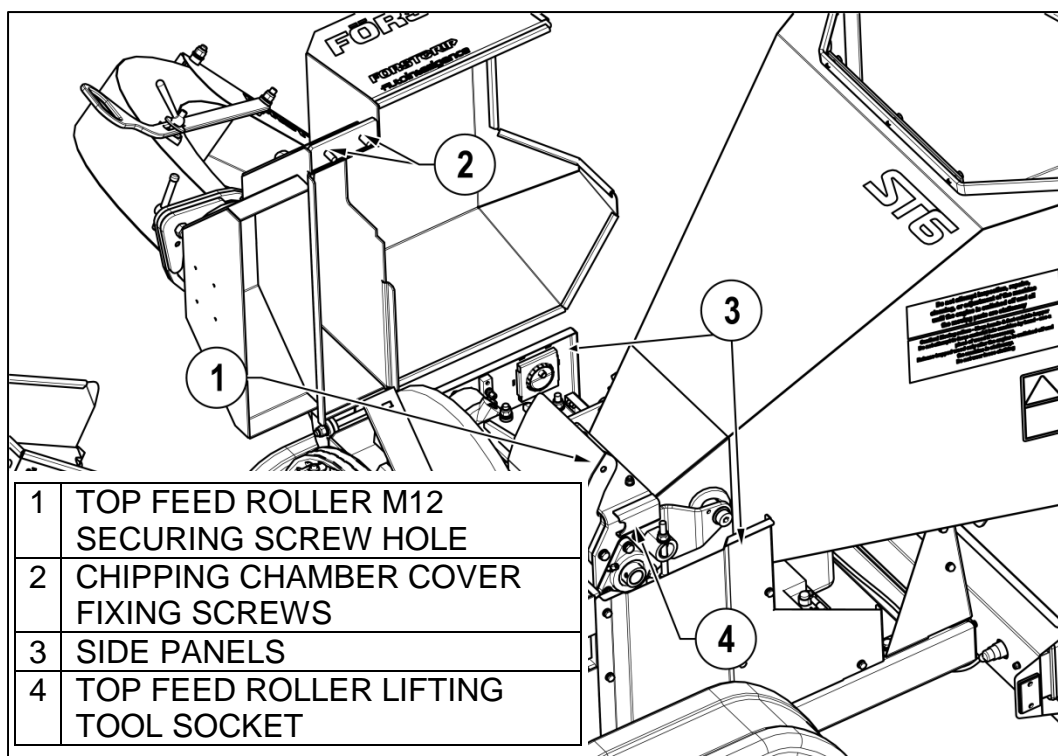

Figure 10

Engine bay

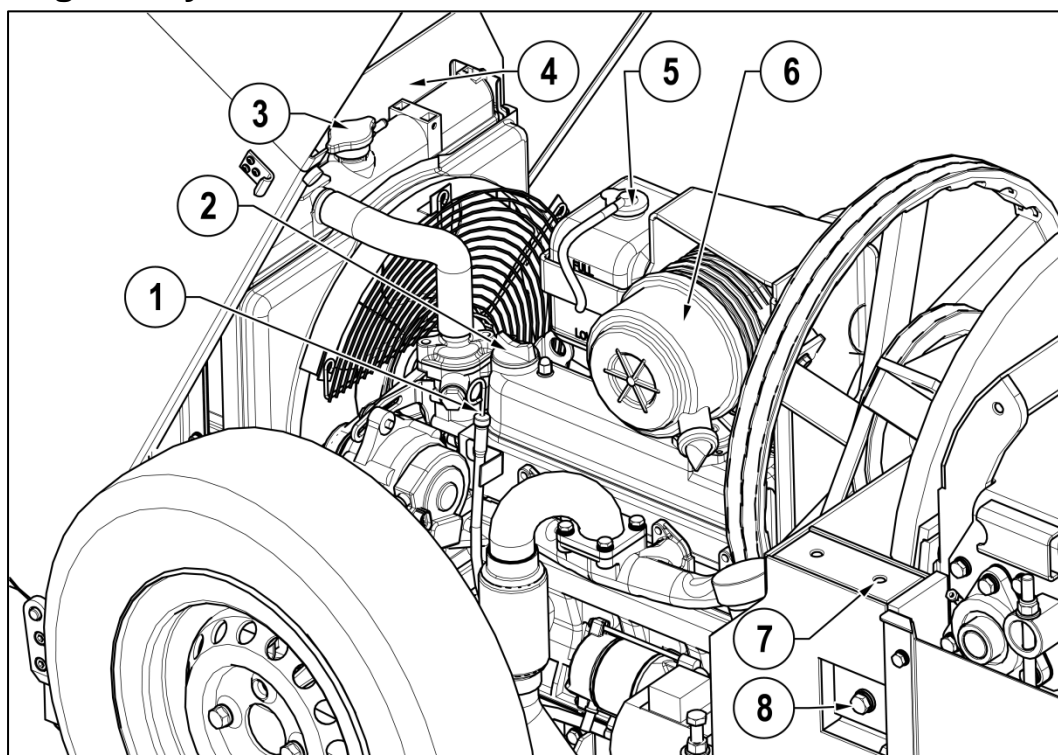
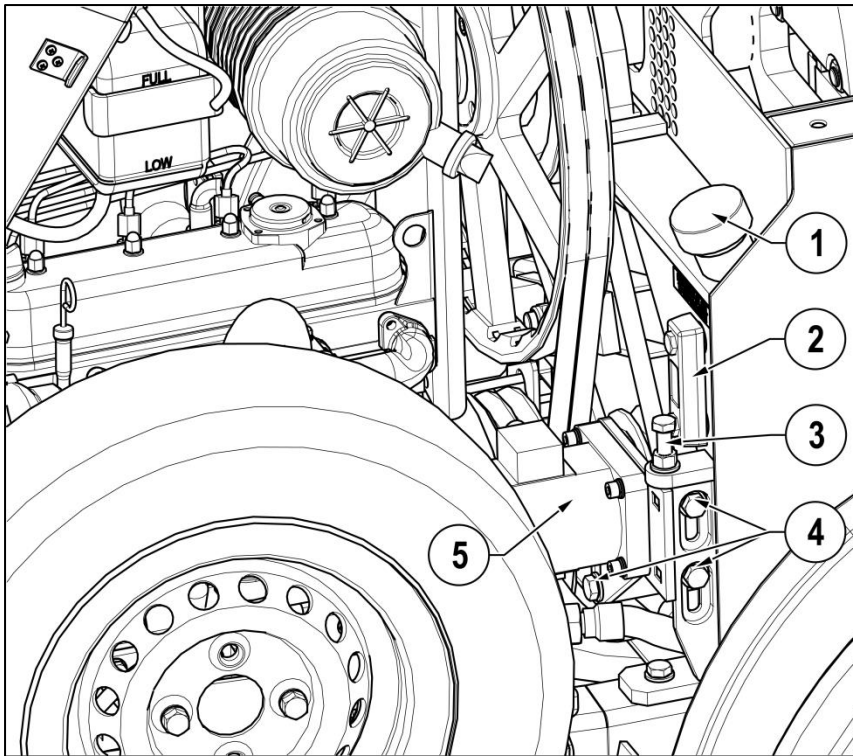

Figure 11

1	OIL DIP STICK
2	ENGINE OIL FILLER CAP
3	RADIATOR FILLER CAP
4	DEBRIS SCREEN
5	RADIATOR RESERVOIR BOTTLE
6	AIR FILTER
7	CHIPPING CHAMBER COVER FIXING
8	ANVIL CLAMP BOLT



1	HYDRAULIC OIL FILLER CAP
2	HYDRAULIC OIL LEVEL SIGHT GLASS
3	PUMP BELT TENSIONER SCREW
4	HYDRAULIC PUMP CLAMP SCREWS
5	HYDRAULIC PUMP

Figure 12

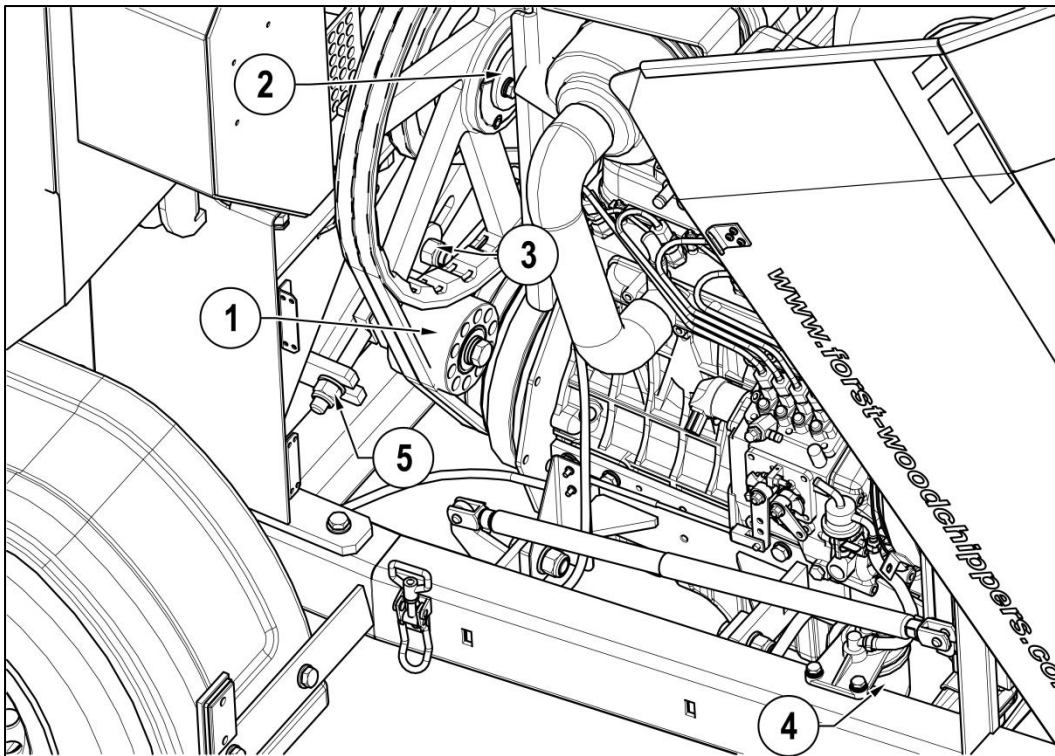
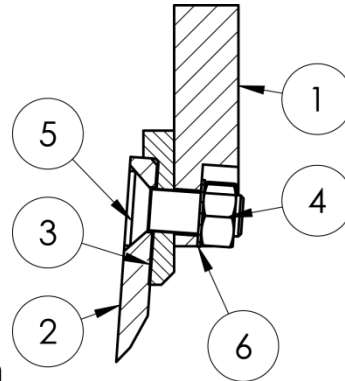

Figure 13

1	FLYWHEEL BELT TENSIONER IDLER PULLEY
2	FLYWHEEL TAPER LOCK RETAINER
3	FLYWHEEL DRIVE BELT TENSION ADJUSTMENT
4	FUEL FILTER
5	FLYWHEEL DRIVE BELT TENSION ADJUSTMENT

Blade sharpening

For optimum performance, blades need to be kept sharp. Minimum safe blade size after sharpening is shown in Figure 14. After sharpening, the blade gap must be re-



set by using a blade shim as shown in

Figure 15. Shims are available in thicknesses of 0.5, 1, 1.5, 2 & 2.5mm as part number 12-03-093. On no occasion must more than one shim be fitted under each blade at any time. A gap of 0.5mm must be set from the inner blade tip to anvil after sharpening by placing an appropriate shim under the blade (also see flywheel assembly). The outer blade tip is automatically set due to the anvil being set at an angle to the blade. With 0.5mm at the inner blade tip, the outer blade tip should be 3mm from the anvil as shown in Figure 16

The complete blade fastener set must be replaced every time blades are changed.

DO NOT Lubricate the Bolts when fitting.

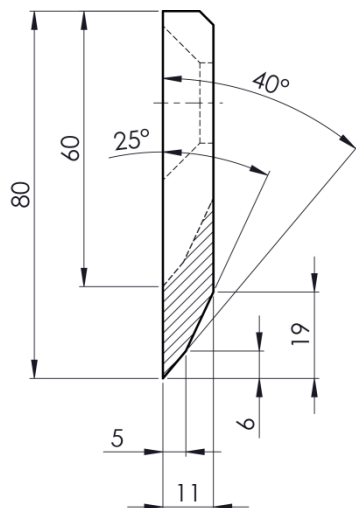

Blade sharpening limit
80mm to 60mm

Figure 14

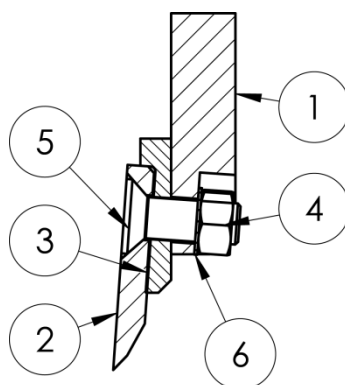

1	Flywheel
2	Flywheel blade
3	Blade shim
4	M16 10.9 hex nut
5	M16 x 45Lg 10.9 CSK hex socket screw
6	M16 serrated lock washer

Figure 15

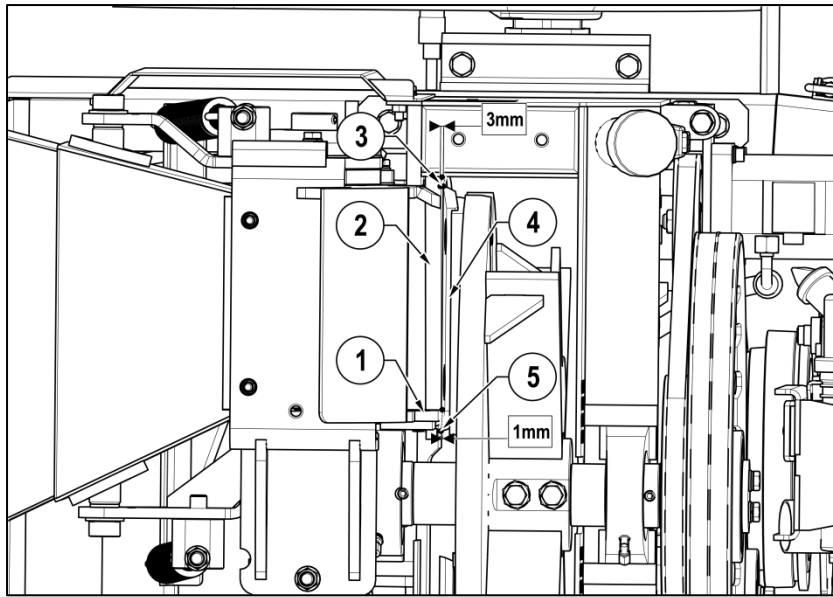

1	SIDE ANVIL
2	ANVIL
3	OUTSIDE BLADE GAP
4	FLYWHEEL BLADE
5	INSIDE BLADE GAP

Figure 16

Hydraulic oil filter

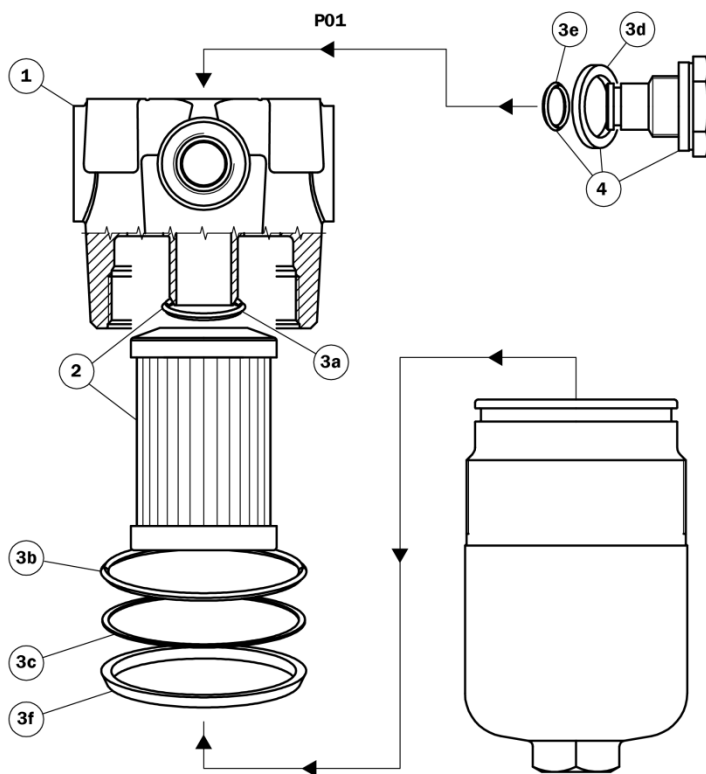

Item	Description	Quantity
1	Complete filter	1
2	Filter element	1
3	Seal kits	1
3a	O-ring for filter element	1
3b	O-ring for housing	1
3c	Anti-extrusion ring	1
3d	Gasket	1
3e	O-ring	1
3f	Protection seal	1
4	Indicator plug	1

Use protective plastic gloves to keep oil off skin, dispose of oil and filter in an environmentally responsible manner.

1. The filter housing is accessed via the left side panel (see covers Figure 9). Thoroughly clean around filler housing before removing to help prevent debris getting into oil.
2. Unscrew filter housing body, remove filter element and allow to drain for 15 minutes before disposal.
3. Screw on and tighten filter body with new seals and filter into filter housing.

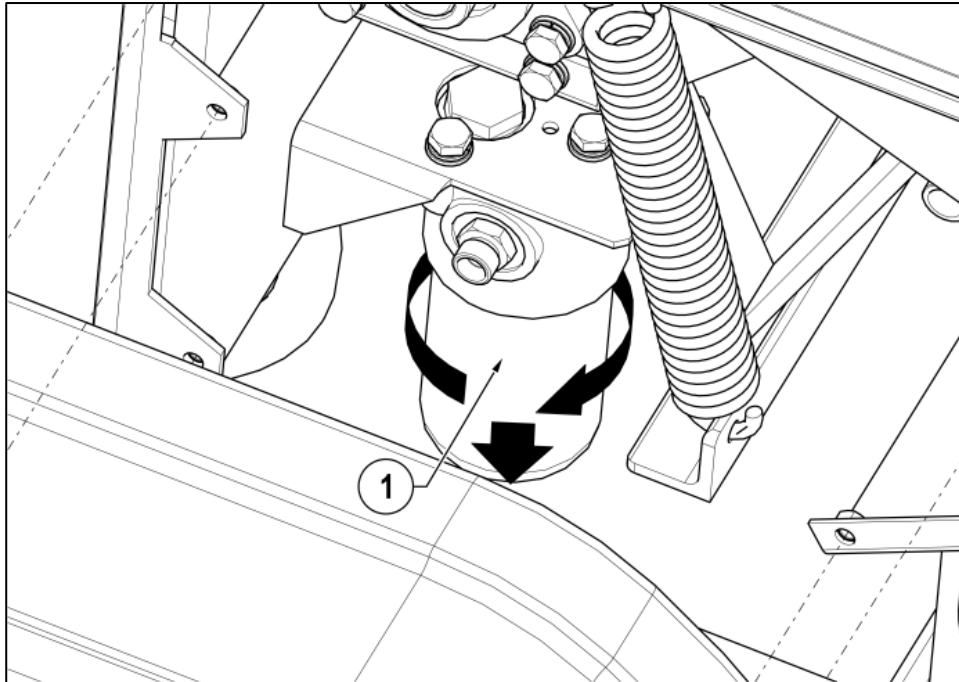

1	UNSCREW FILTER BODY TO REPLACE FILTER ELEMENT
---	---

Oils, Fluids and Lubricants

Engine Oil: HD SAE 15w40

Please consult your supplied Kubota engine operator's manual for oil quantities relating to your engine type.

Hydraulic Oil: ISO VG 46.

It is advised that the oil is checked and topped up to the RED LINE on the sight glass, when the machine is cold and on a level surface.

Anti-Freeze: Mono-ethylene Glycol at a 50% mix ratio.

Please consult your supplied Kubota engine operator's manual for coolant quantities relating to your engine type.

Grease: Lithium EP2 General Purpose

Drive belt tension

Both Hydraulic pump and flywheel V belts must be checked for tension and condition. If any belt shows signs of wear, surface damage, shredding, excessive glazing, or have been stretched to their limit, they must be replaced. Multiple belt drives must have all belts replaced at the same time. Belts that are too slack will cause poor cutting performance, excessive belt and pulley wear.

All drive belts are located under the engine cover as shown in Figure 12 and Figure 13 and tension checked at arrows shown in Figure 17. Check and set tension as follows:

1. Slacken clamp screw(s) or nut.
2. Hydraulic pump adjuster screw requires its lock nut to be slackened.
3. Turn adjuster nut or screw to tension belt until 4.5Kg force at the belt longest centre span deflects by 6mm (see Figure 17). Can be approximated by firmly gripping belt between finger and thumb and twisting. The belt should not be able to be rotated more than 90°.
4. Tighten all lock nuts, nuts and clamp screws.
5. Run machine and test.
6. Check belt tension.

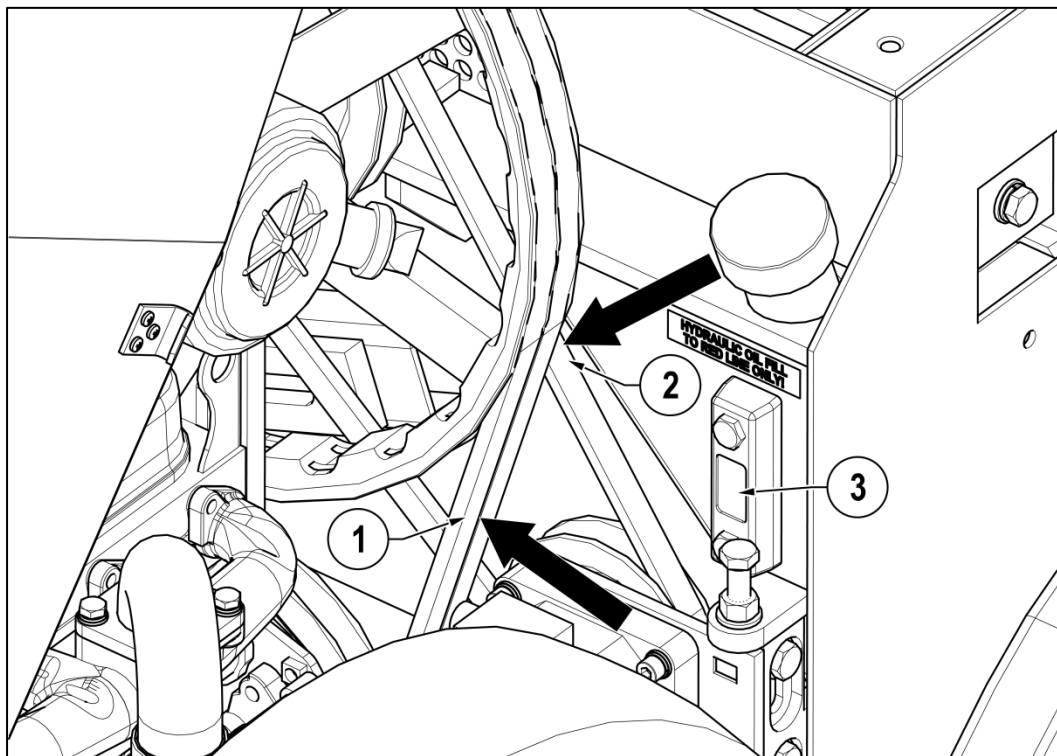

Figure 17

1	FLYWHEEL DRIVE BELTS. CHECK TENSION HERE
2	HYDRAULIC PUMP DRIVE BELT. CHECK TENSION HERE
3	HYDRAULIC OIL LEVEL IN SIGHT GLASS

Battery

Battery safety information

1. Battery acid is highly corrosive. For safety reasons, wear eye protection when handling a battery. Do not tilt battery as acid could escape from vents.
2. Keep children away from acid and batteries.
3. Battery emits highly explosive hydrogen gas when charged. Do not allow fires, sparks, naked flames or smoking near the battery. Also avoid electrostatic discharges and electrical sparks when dealing with cables and electrical equipment.
4. First aid. If acid is splashed into eyes, immediately rinse with clean water for several minutes and consult a doctor without delay. If acid is swallowed, consult a doctor immediately. Neutralise acid splashes on the skin and clothes immediately with acid neutraliser (a solution of water and soda/baking soda) or soap suds, and rinse with plenty of clean water.
5. Battery case can become brittle. To help avoid this, do not store batteries in direct sunlight. Discharged batteries could freeze so store in a frost-free area.
6. Dispose of old batteries at an authorised collection point. Never dispose of in household waste.

Storage and transport

1. As batteries are acid filled, always store and transport them upright and prevent from tilting to avoid acid escape.
2. Store in a cool, dry, frost free place.
3. Do not remove the protective positive terminal cap.
4. Run a First-in First-Out (FIFO) warehouse management system.

Initial operation

1. Batteries are filled with acid at a density of 1.28g/ml at 15°C during manufacture and are ready for use.
2. Recharge in case of insufficient starting power (see charging).

Battery removal & maintenance

To remove and replace battery:

1. Switch off engine and all electrical equipment.
2. To gain access to the battery, remove left side panel as shown in Figure 9 & Figure 18.
3. Avoid short circuiting the battery terminals and from positive to any metal machine part. Loose metal parts and tools commonly cause this.
4. Remove excessive debris from around the battery.
5. First remove negative lead at the battery, then the positive. Battery terminals are the take-off type and fastened with an M6 screw in to a ferrule on the cable end.

6. Slacken the M8 battery clamp screw.
7. Remove battery. Clean with a moist anti-static cloth to avoid electrostatic discharge and explosion risk. Charge and check electrolyte level if appropriate.
8. Clean out battery tray. Apply a thin film of petroleum jelly to terminals to prevent corrosion.
9. Replacement is the reversal of removal. Ensure to replace/fit any vent pipes. Leave at least one vent open otherwise there is an explosion risk. This also applies to old batteries removed for disposal/recycling. Swap new battery positive terminal protective cover to the old battery positive terminal to help prevent short circuits and sparks.

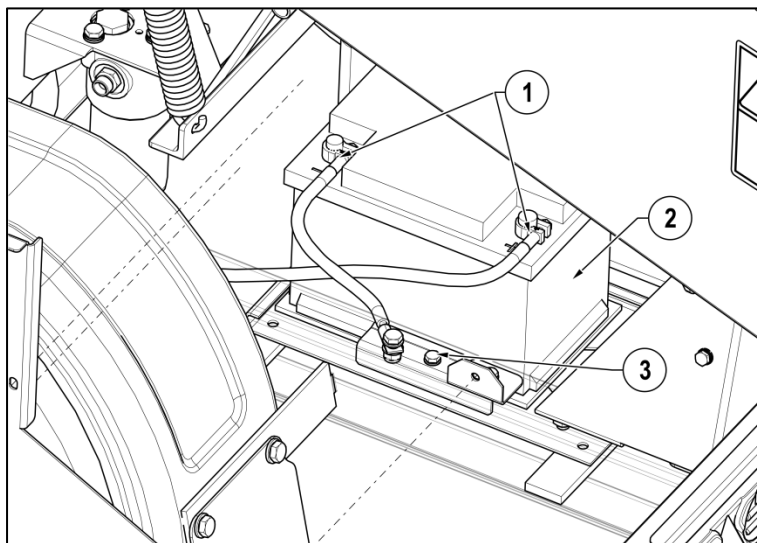

1	TAKE-OFF BATTERY TERMINALS FASTENED WITH M6 SCREW
2	BATTERY
3	BATTERY CLAMP M8 SCREW

Figure 18

Charging

1. Remove battery from machine, disconnect negative terminal first.
2. Ensure good ventilation.
3. Use suitable direct current mains chargers only.
4. Connect battery positive terminal to charger output positive. Connect the negative terminal accordingly.
5. After connection, switch on charger. When charging is complete, switch off charger then disconnect battery.
6. Charging current recommendation is 10% of the battery Ah power rating.
7. Use a charger with a constant charging voltage of 14.4V.
8. If the acid temperature rises above 38°C, stop charging.
9. The battery is fully charged when the charging voltage or acid specific gravity has stopped rising for two hours.

Jump starting

1. Use a standardised jumper cable to DIN 72553 only and follow the instructions.

2. Only use batteries of the same voltage.
3. Switch off ignition on machine and support vehicle. The two must not touch and all lights/equipment must be turned off.
4. Referring to Figure 19, connect in the sequence of 1 – 2 – 3 – 4 as shown and as follows: Connect one end of the red jump lead to the machine battery positive (+) terminal.
5. Connect the other end of the red jump lead to the support vehicle battery positive (+) terminal.
6. Connect one end of the black jump lead to the support vehicle battery negative (-) terminal.
7. Connect other end of the black jump lead to a machine metal part away from the battery eg. onto the engine from under the chassis.
8. Make sure that the jump leads will not come into contact with moving parts.
9. Start the support vehicle engine and run at a medium idle speed for 15 seconds.
10. Start machine and run for 15 seconds.
11. Disconnect jump leads in the reverse order 4 – 3 – 2 – 1.

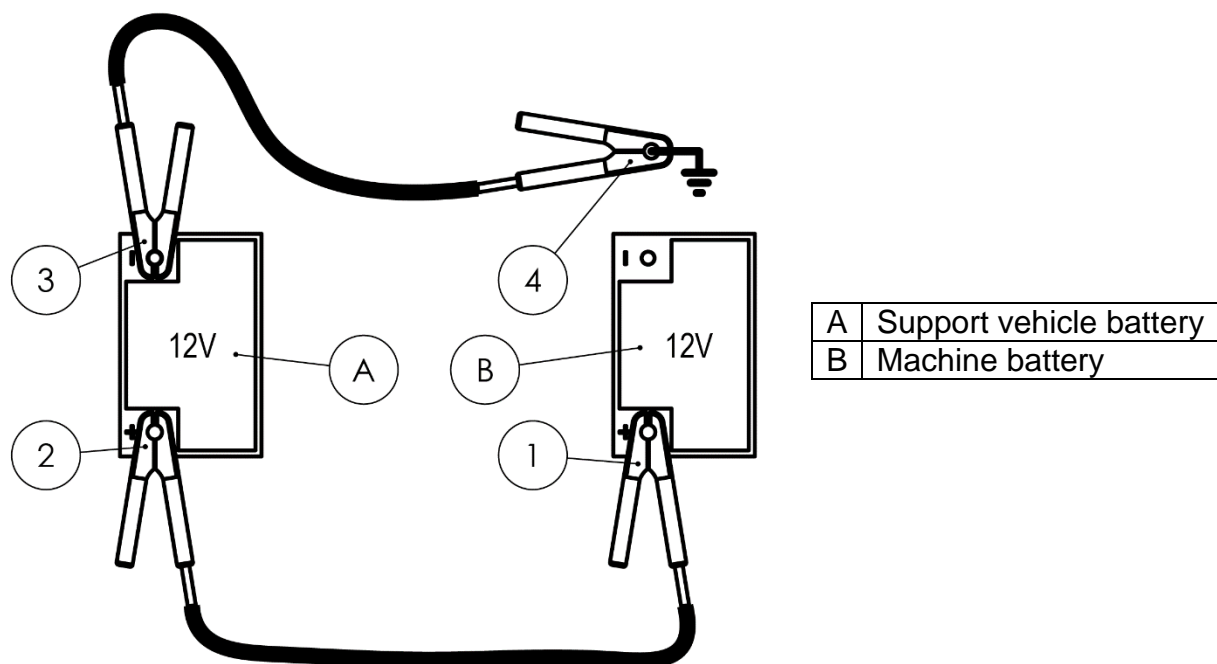

Figure 19

Taking battery out of service

1. Charge the battery and store in a cool but frost free place or on the vehicle with the negative terminal disconnected.
2. Check the battery charge at regular intervals. Recharge if necessary.

Parts lists

Hopper tray touch sensor 12-A-020

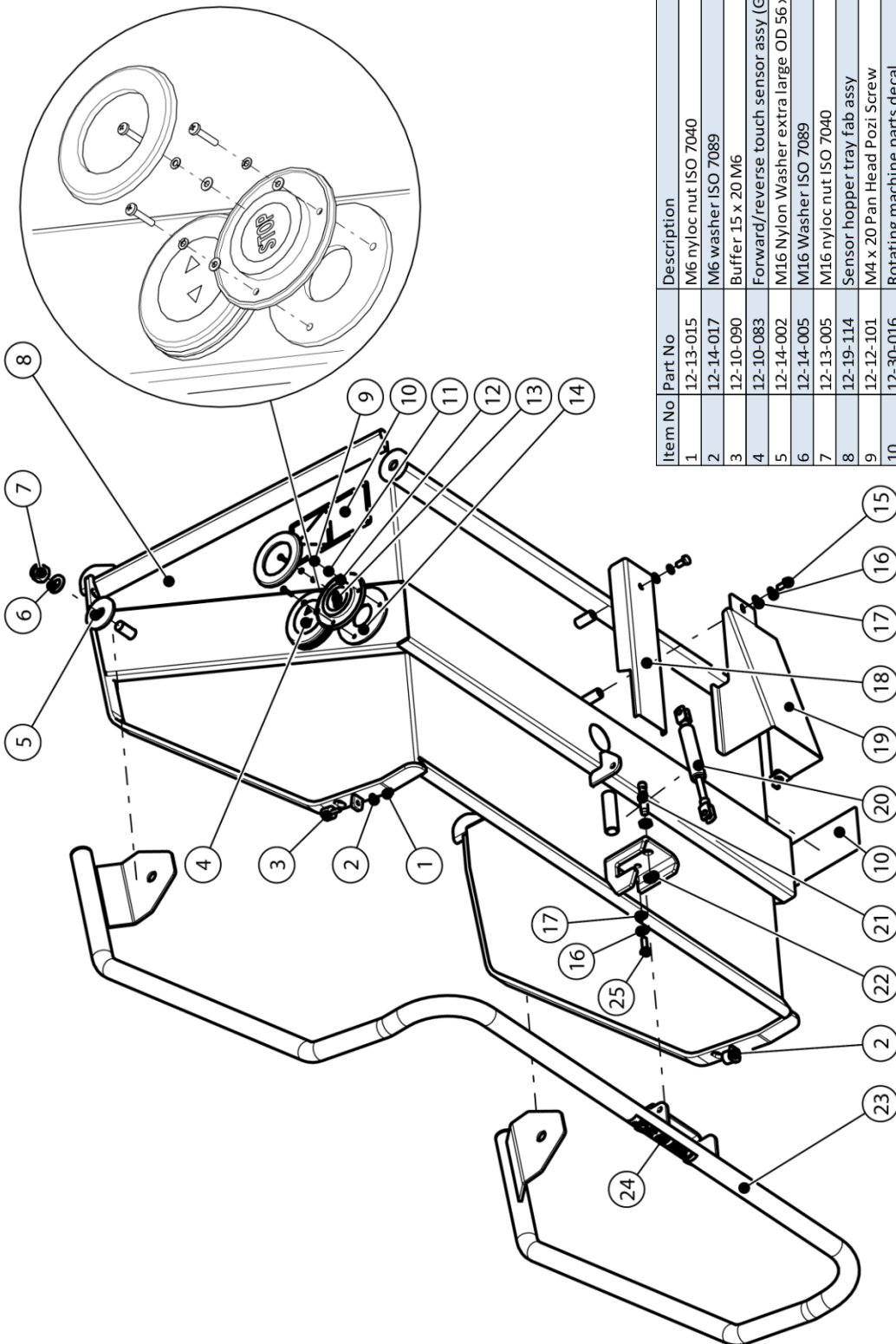

Item No	Part No	Description	Quantity
1	12-13-015	M6 nyloc nut ISO 7040	2
2	12-14-017	M6 washer ISO 7089	2
3	12-10-090	Buffer 15 x 20 M6	2
4	12-10-083	Forward/reverse touch sensor Assy (Green)	2
5	12-14-002	M16 Nylon Washer extra large OD 56 x 5 THK ISO 7094	2
6	12-14-005	M16 Washer ISO 7089	2
7	12-13-005	M16 nyloc nut ISO 7040	2
8	12-19-114	Sensor hopper tray fab Assy	1
9	12-12-101	M4 x 20 Pan Head Pozi Screw	12
10	12-30-016	Rotating machine parts decal	2
11	12-14-027	M4 Serrated washer DIN 128	12
12	12-14-020	M4 washer ISO 7089	12
13	12-10-080	Stop touch sensor Assy	2
14	12-05-044	Touch sensor gasket	4
15	12-12-404	M8 x 16 Lg 8.8 Hex Head screw	2
16	12-14-014	M8 Spring washer DIN 128	3
17	12-14-013	M8 washer ISO 7089	3
18	12-03-083	Cable cover	1
19	12-03-104	Trip mech guard fab Assy	1
20	12-10-084	Gas spring 22 DIA 50 stroke	1
21	12-10-071	Inductive proximity sensor kit (white tip)	1
21a	12-10-072	Inductive proximity sensor kit (orange tip)	1
23	12-19-117	Sensor trip bar fab Assy	1
24	12-30-017	Push to stop decal	1
25	12-12-401	M8 x 25 Lg 8.8 Hex Head screw	1

Chipping chamber assembly 12-A-005

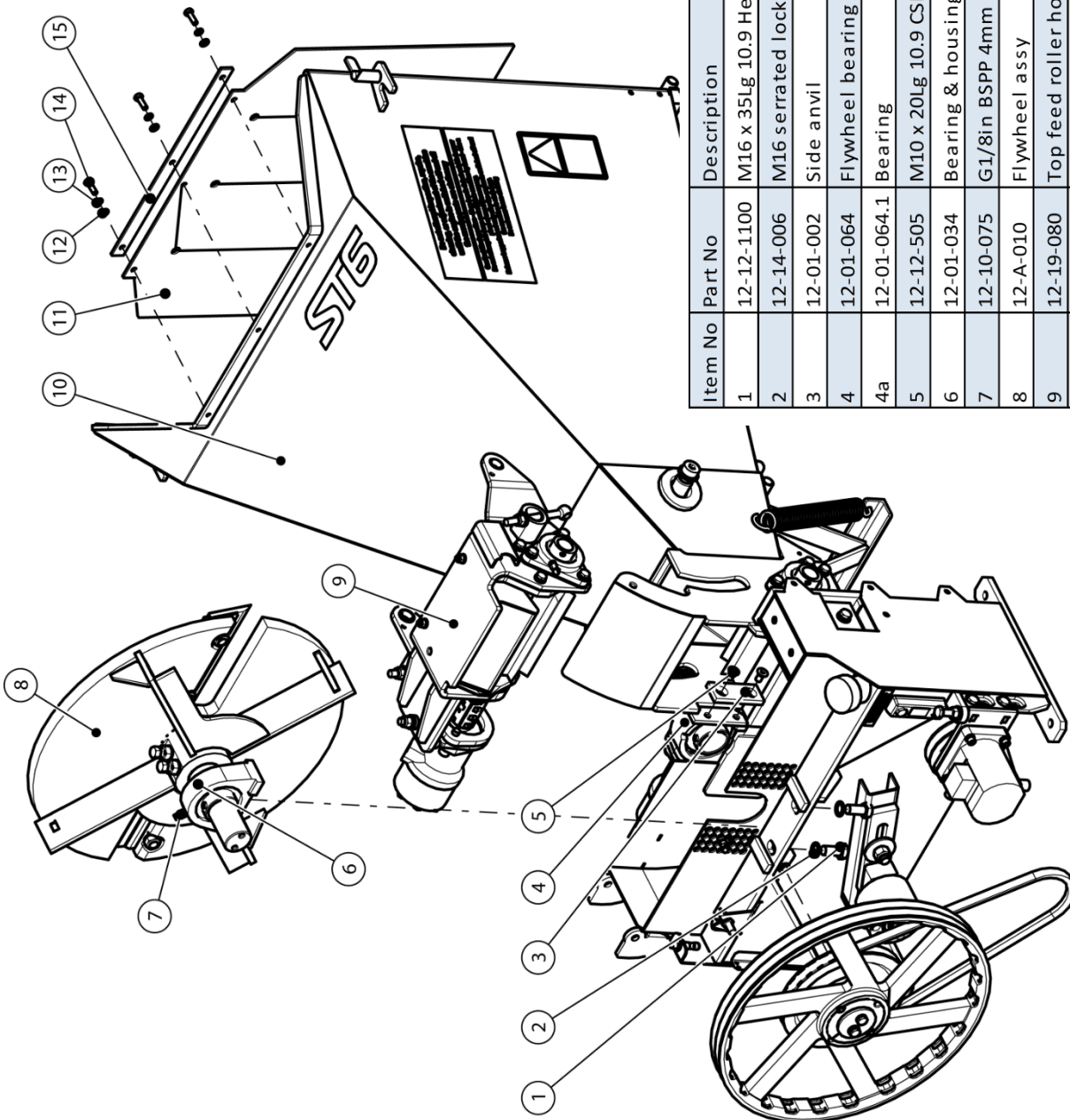

Item No	Part No	Description	Quantity
1	12-12-1100	M16 x 35Lg 10.9 Hex Head screw	4
2	12-14-006	M16 serrated lock washer DIN 6798-A17	4
3	12-01-002	Side anvil	1
4	12-01-064	Flywheel bearing housing	1
4a	12-01-064.1	Bearing	1
5	12-12-505	M10 x 20Lg 10.9 CSK hex socket screw ISO 10642	2
6	12-01-034	Bearing & housing	1
7	12-10-075	G1/8in BSP 4mm male stud coupling	1
8	12-A-010	Flywheel assy	1
9	12-19-080	Top feed roller housing	1
10	12-19-029	Chipping chamber with hopper	1
11	12-05-017	Safety curtain	1
12	12-14-013	M8 washer ISO 7089	2
13	12-14-014	M8 Spring washer DIN 128	2
14	12-12-401	M8 x 25 Lg 8.8 Hex Head screw	3
15	12-05-016	Curtain clamp	1

Chipping chamber assembly 12-A-005. Bottom feed.

Item No	Part No	Description	Quantity
1	12-01-014	Feed roller	1
2	12-01-016E	Bottom feed roller shaft	1
3	12-20-004	Rectangular key 30x8x7	1
4	12-14-009	M10 Washer ISO 7089	2
5	12-14-010	M10 Spring Washer DIN 128	2
6	12-12-509	M10 x 35Lg 8.8 Hex Head screw	2
7	12-01-049	Rigid shaft coupling 25 ID	1
8	12-12-308	M5 x 20Lg Socket Head Cap Screw	4
9	12-19-132	Feed motor bracket fab assy	1
10	12-19-133	Feed motor clamp	1
11	12-24-005	Hydraulic motor 199.6cc/rev	1
12	12-12-609	M12 x 45Lg 8.8 Socket Head Cap Screw	2
13	12-01-062	Feed bearing clamp	1
14	12-01-052	Oilite 30 ID spherical bearing	1
15	12-01-053	Feed roller spherical bearing housing	1
16	12-20-005	Rectangular key 40x10x8	1
17	12-01-044	M10 x 25Lg 10.9 Cone Point Screw	1
18	12-13-003	M12 nyloc nut ISO 7040	1
19	12-14-003	M12 Washer ISO 7089	1
20	12-10-127 Part C	M12 spherical washer	1
21	12-10-127 Part D	M12 spherical dished washer	1

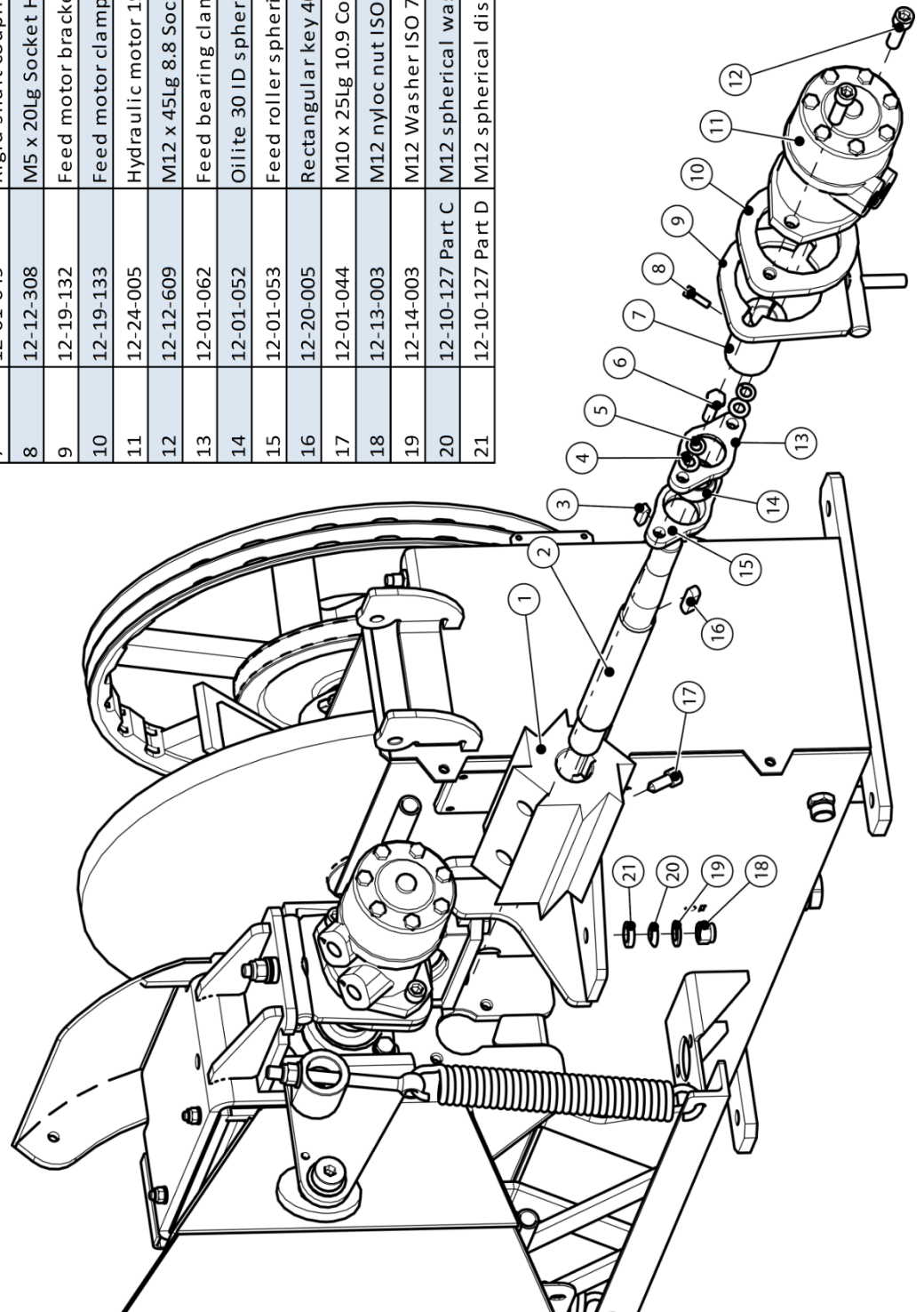

Chipping chamber assembly 12-A-005. Bottom feed & anvil.

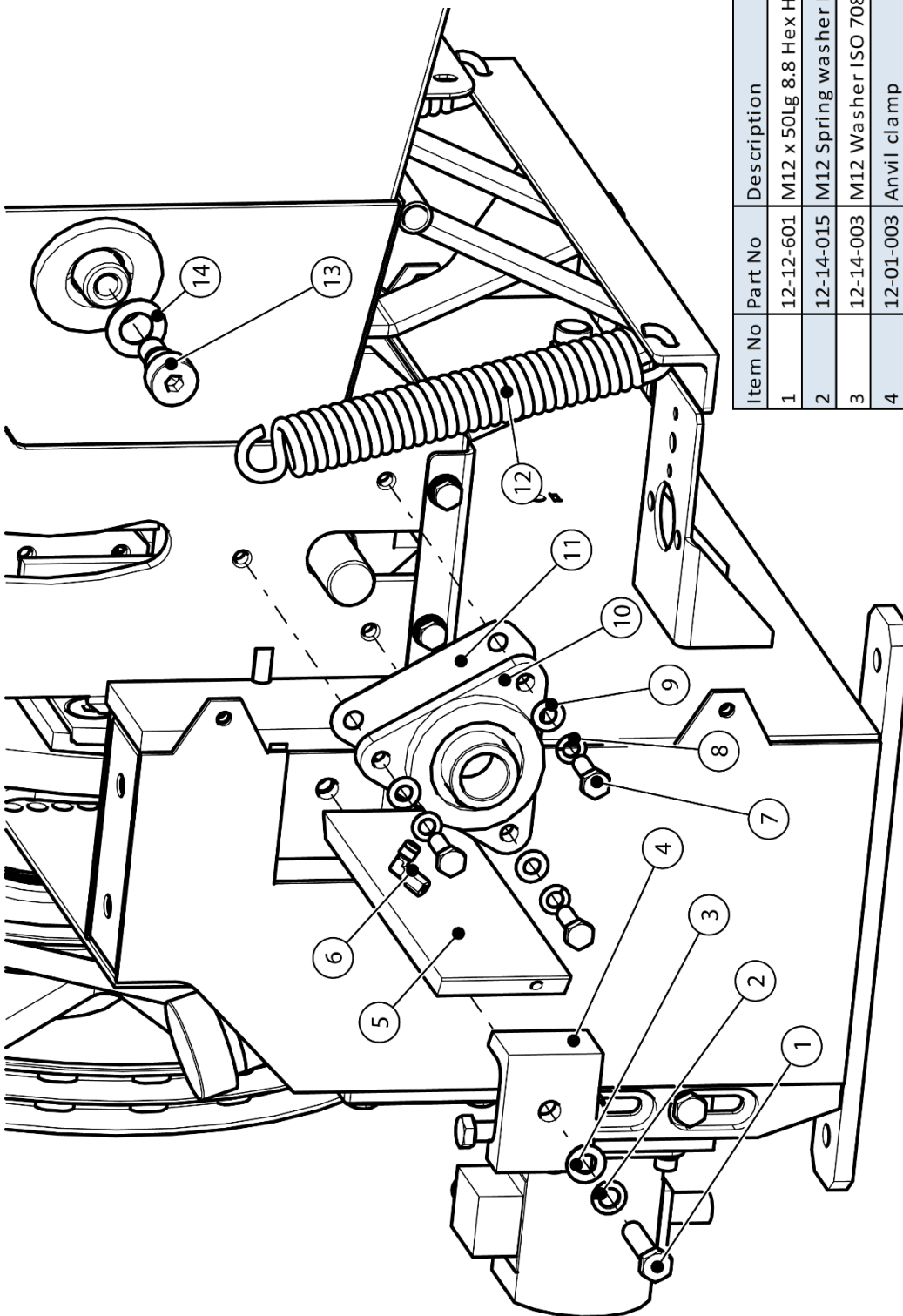

Item No	Part No	Description	Quantity
1	12-12-601	M12 x 50Lg 8.8 Hex Head screw	1
2	12-14-015	M12 Spring washer DIN 128	1
3	12-14-003	M12 Washer ISO 7089	1
4	12-01-003	Anvil clamp	1
5	12-01-013	Anvil	1
6	12-10-094	R1/8in BSPT 4mm male stud elbow	1
7	12-12-502	M10 x 30Lg 8.8 Hex Head screw	3
8	12-99-008	M10 Serrated Washer	3
9	12-14-009	M10 Washer (if required)	3
10	12-11-005	Self Aligning Flange Bearing 2Z 30 ID	1
11	12-03-042	Feed roller bearing shim	1
12	12-15-002	Tension spring 7.01 wire 23.98 ID 31 turns	2
13	12-01-008	Shoulder screw M16 x 14Lg	2
14		M20 Nylon Washer (not required)	2

Chipping chamber assembly 12-A-005. Drive

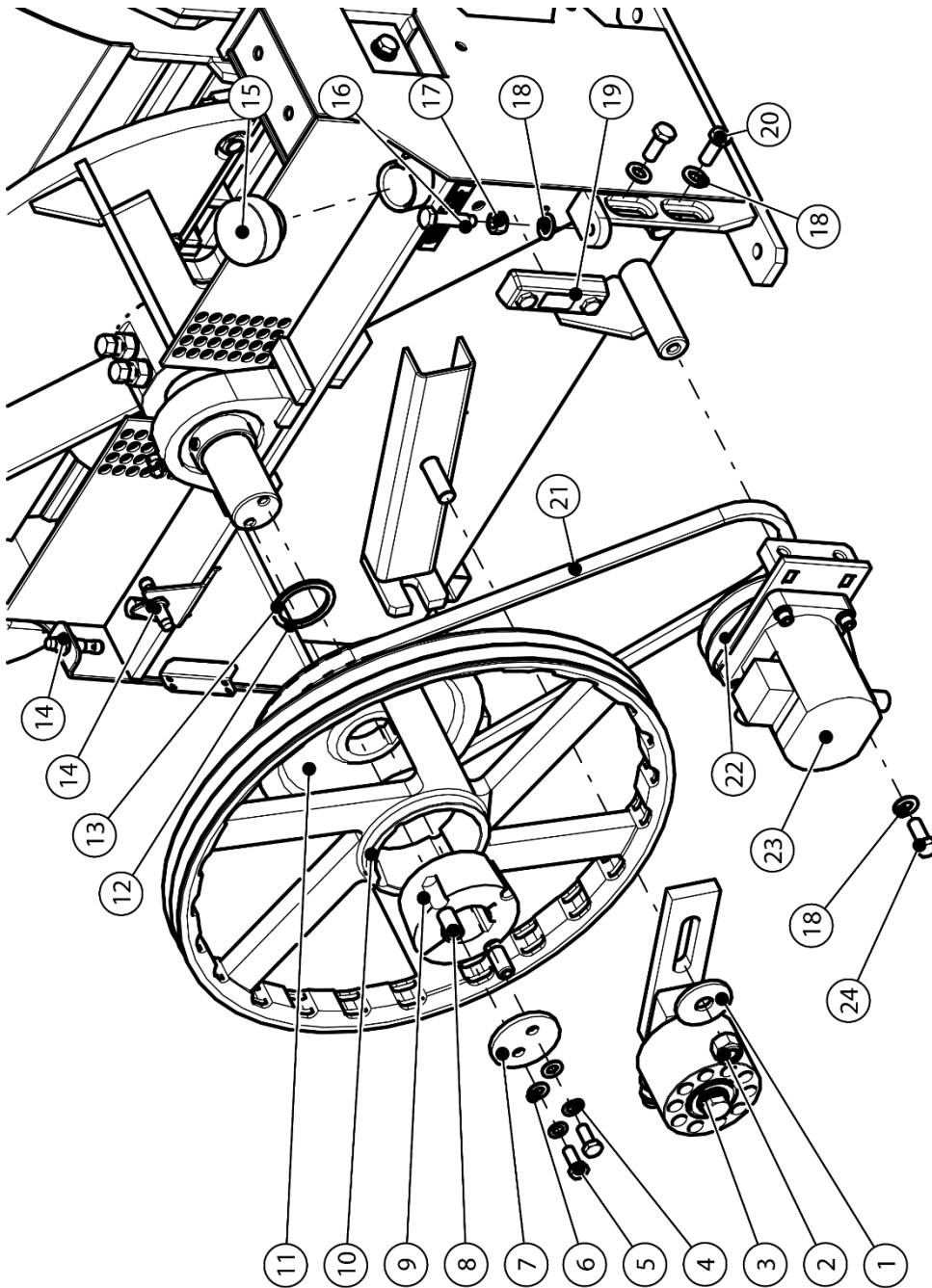

Item No	Part No	Description	Quantity
13	12-10-086	Shim 50 ID x 62 OD x 1 THK DIN 988	1
14	12-10-071	Inductive proximity sensor kit	2
15	12-10-015	Hydraulic oil filler cap - plastic	1
16	12-01-029	M12x50Lg adjuster screw	1
17	12-13-002	M12 Hex nut ISO 4034	1
18	12-14-003	M12 Washer ISO 7089	4
19	12-24-003	Oil level glass	1
20	12-12-603	M12 x 30Lg 8.8 Hex Head screw	2
21	12-10-058	V belt 17 x 1410mm Ld	1
22	12-A-022	Hydraulic pump assy (see P43)	1
23	12-24-004	Hydraulic pump	1
24	12-12-603	M12 x 30Lg 8.8 Hex Head screw	1

Item No	Part No	Description	Quantity
1	12-14-001	M16 Washer extra large OD 56 x 5 THK ISO 7094	1
2	12-13-005	M16 nyloc nut ISO 7040	1
3	12-A-012	Flywheel belt tensioner assy (see P41)	1
4	12-14-010	M10 Spring Washer DIN 128	2
5	12-12-506	M10 x 25Lg 8.8 Hex Head screw	2
6	12-14-009	M10 Washer ISO 7089	2
7	12-19-063	Pulley retainer	1
8		Comes with taper lock	2
9	12-10-038	Taper lock bush 50 ID	1
10	12-10-040	Pulley 507 OD x 44 wide 2 groove	1
11	12-01-039	Pulley 231 OD x 25 wide 1 groove	1
12	12-10-085	Shim 50 ID x 62 OD x 0.5 THK DIN 988	1

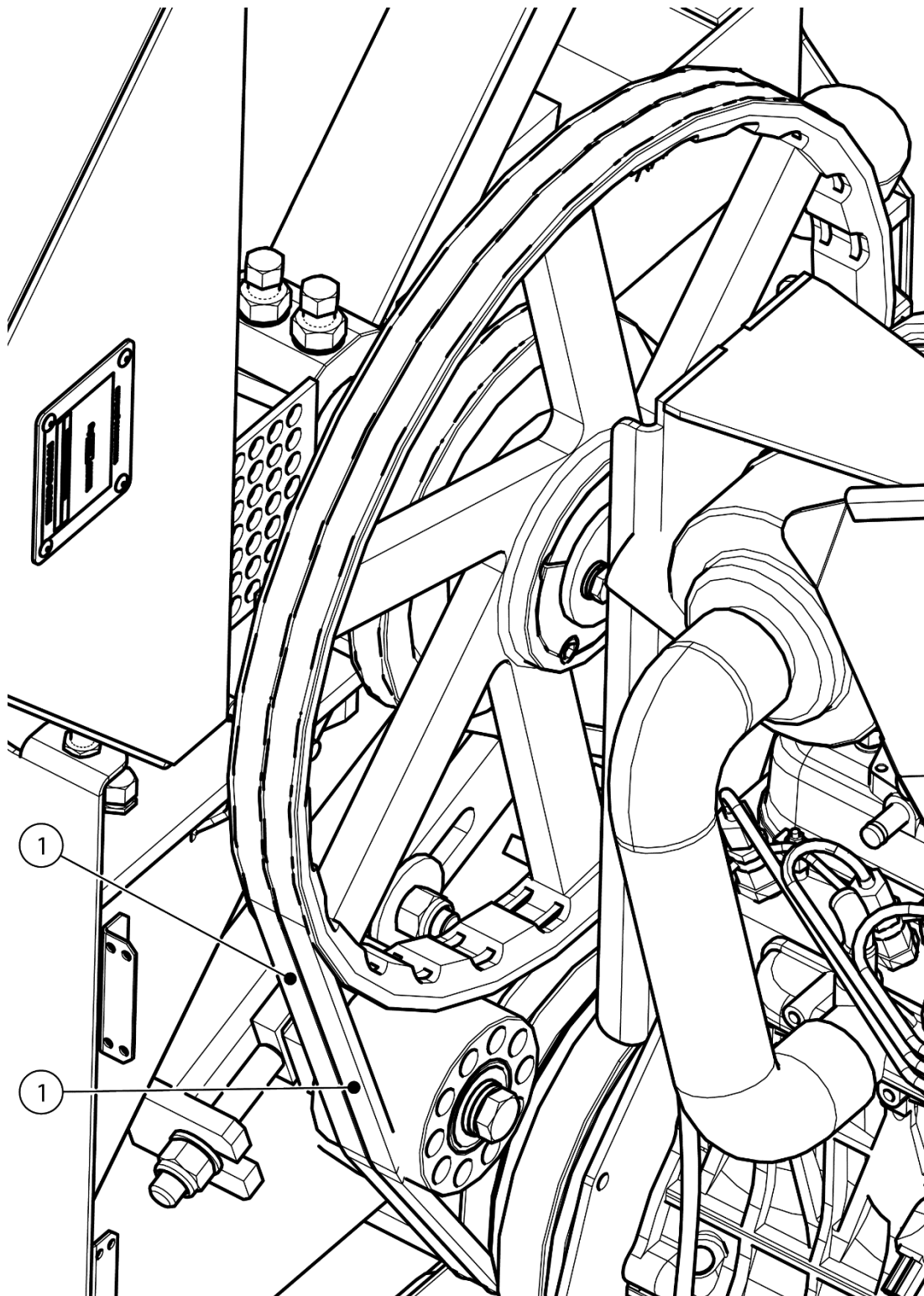
Chipping chamber assembly 12-A-005. Flywheel drive.

Item No	Part No	Description	Quantity
1	12-10-056	V belt 17 x 1975mm Ld	2

Chipping chamber assembly 12-A-005. Bottom feed roller cover.

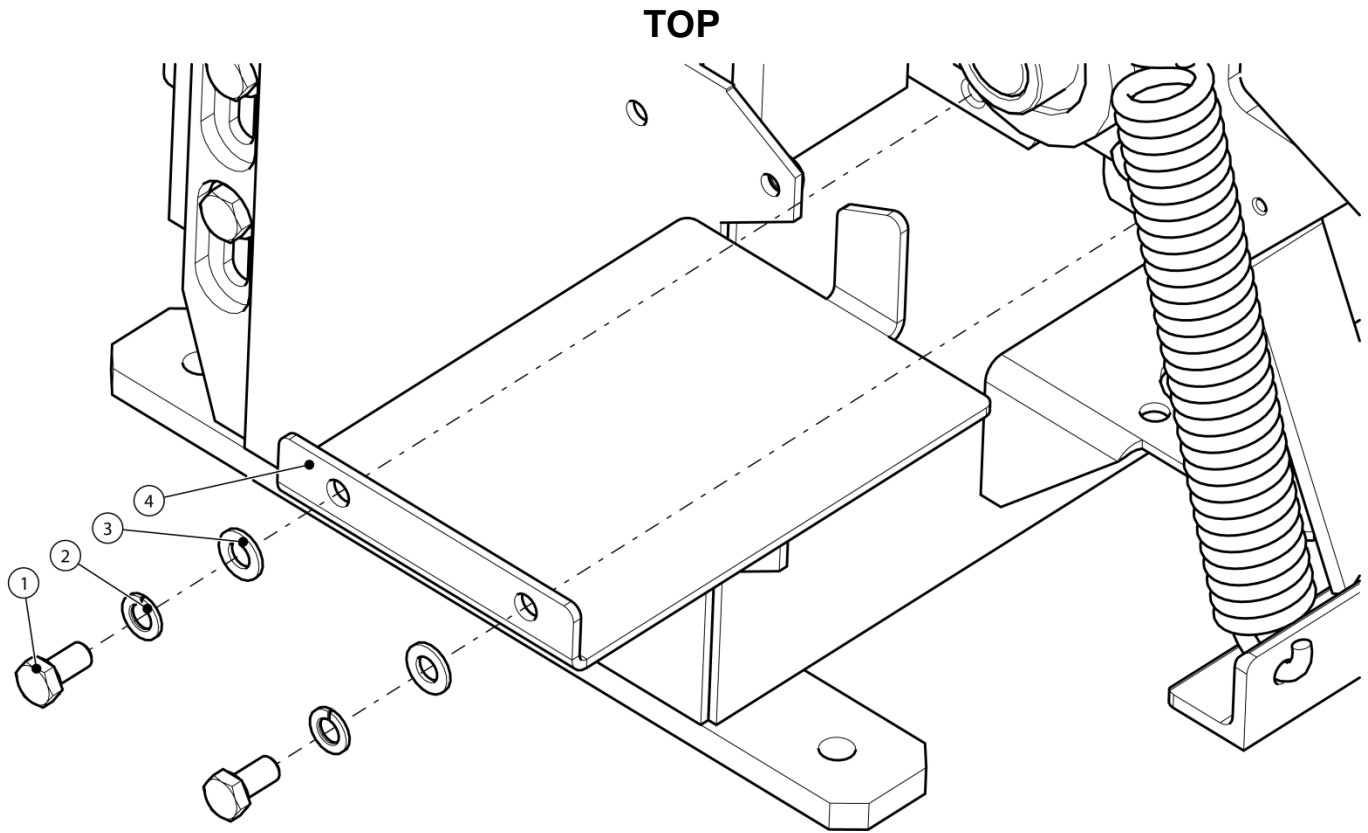

Item No	Part No	Description	Quantity
1	12-12-504	M10 x 20Lg 8.8 Hex Head screw	2
2	12-14-010	M10 Spring Washer DIN 128	2
3	12-14-009	M10 Washer ISO 7089	2
4	12-03-045	Feed roller cover	1

Chute assembly 12-A-007

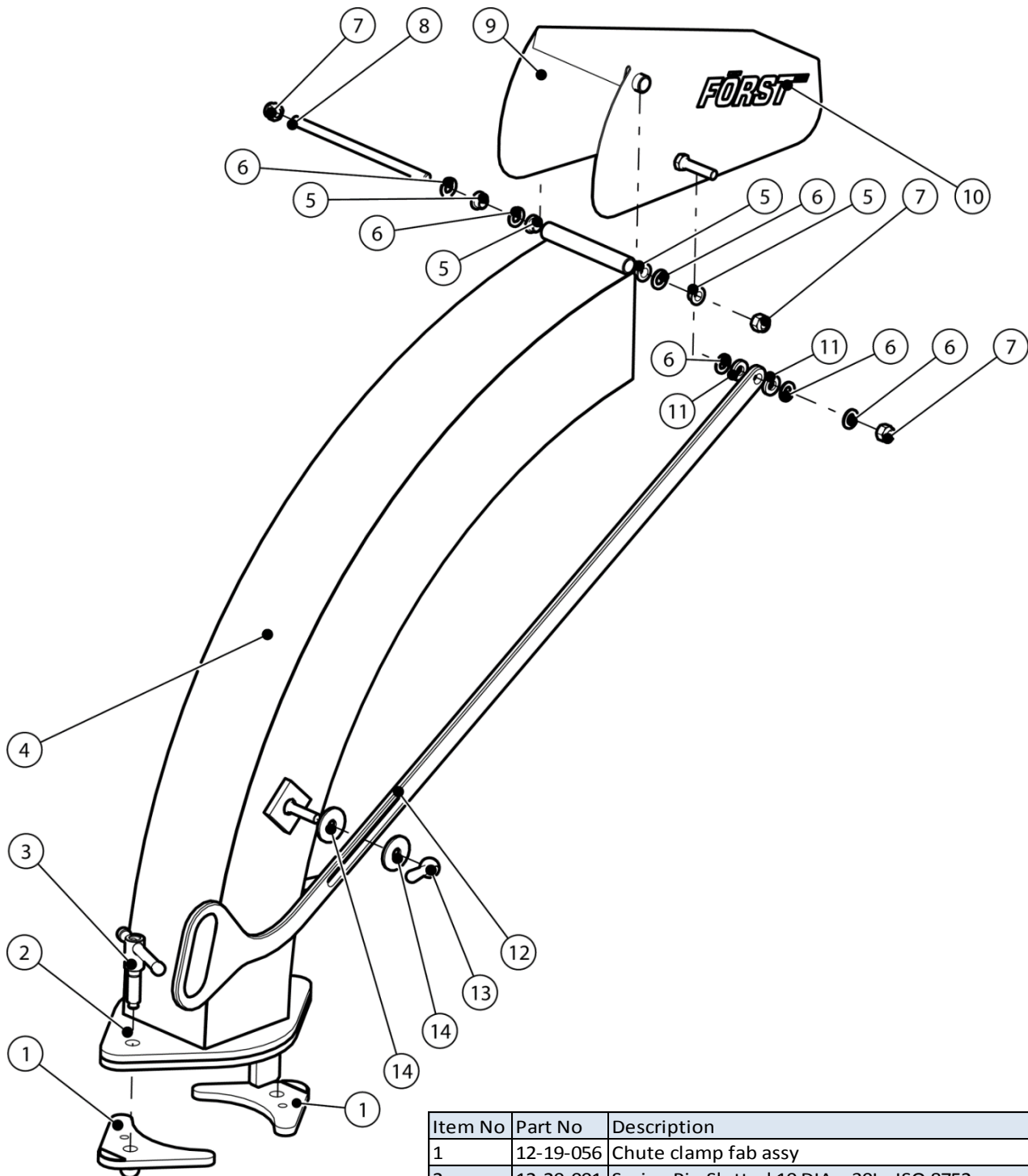

Item No	Part No	Description	Quantity
1	12-19-056	Chute clamp fab assy	2
2	12-20-001	Spring Pin Slotted 10 DIA x 30Lg ISO 8752	2
3	12-10-005	M16 T bar screw	2
4	12-19-051	Chute fab assy	1
5	12-11-007	Plain bearing 12 ID, 16 OD, 22 flange x 10 Lg	4
6	12-14-003	M12 Washer ISO 7089	6
7	12-13-003	M12 nyloc nut ISO 7040	3
8	12-01-043	Hood hinge stud	1
9	12-19-151	Chute hood fab assy	1
10	12-30-024	Forst small orange decal	2
11	12-15-020	M12 Elastomer washer OD 25-ID 12 x 5 THK	2
12	12-19-055	Chute handle - standard	1
13	12-10-004	M12 female steel handle	1
14	12-14-004	M12 Washer extra large OD 44 x 4 THK ISO 7094	2

Top feed roller assembly 12-A-008

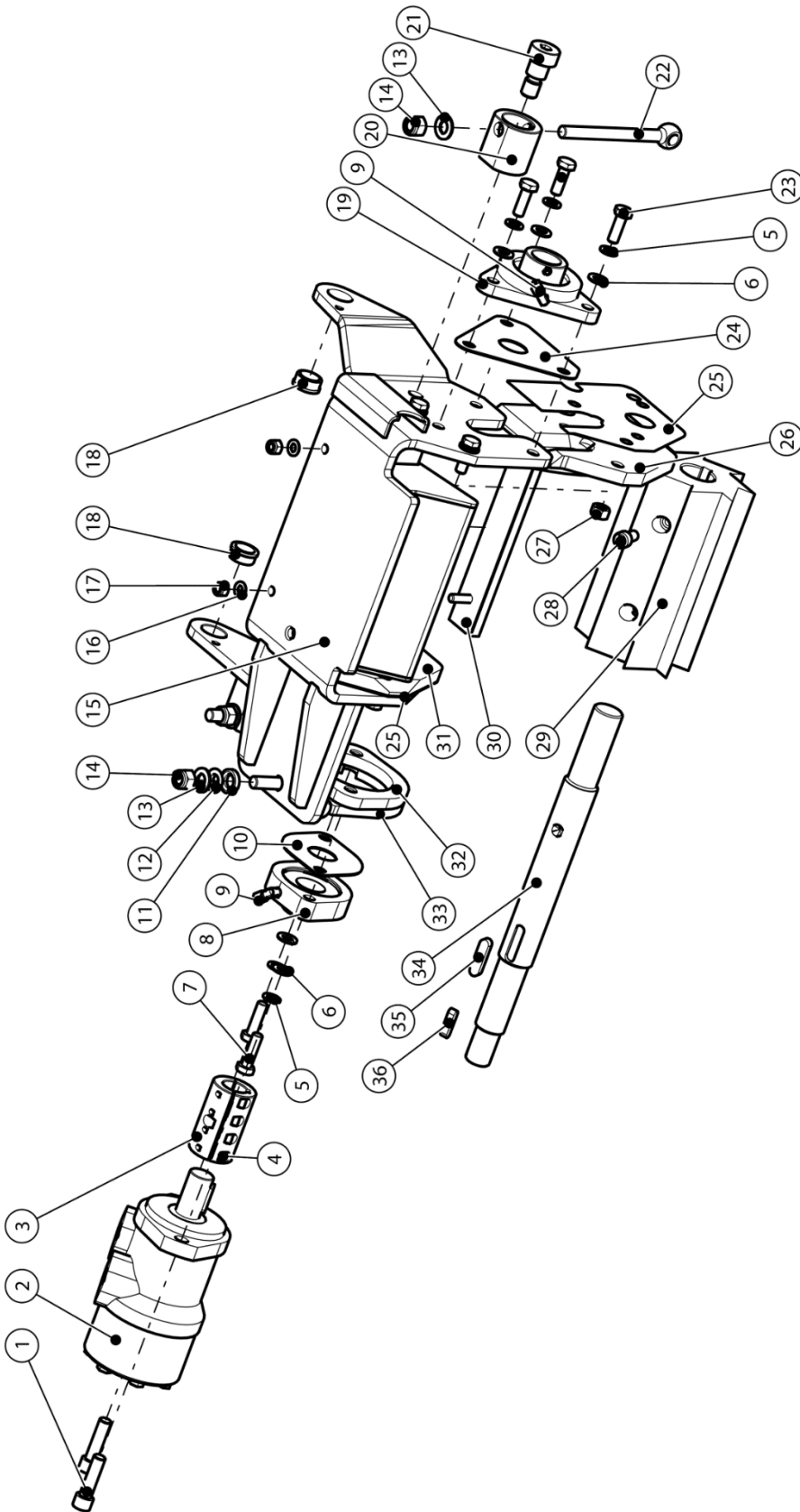

Item No	Part No	Description	Quantity
19	12-11-005	Self Aligning Flange Bearing 2Z 30 ID	1
20	12-01-061	Feed adjuster collar	2
21	12-01-008	Shoulder screw M16 x 14Lg	2
22	12-12-613	M12 x 140 eyebolt DIN 444	2
23	12-12-502	M10 x 30Lg 8.8 Hex Head screw	7
24	12-03-042	Feed roller bearing shim	1
25	12-03-106	Feed cheek shim 30 DIA shaft	2
26	12-01-059	Feed cheek LH 32mm slot	1
27	12-13-006	M10 Hex nut	4
28	12-01-044	M10 x 25Lg 10.9 Cone Point Screw	1
29	12-01-014	Feed roller	1
30	12-02-003	Top feed roller stop	1
31	12-01-060	Feed cheek RH 32mm slot	1
32	12-19-133	Feed motor clamp	1
33	12-19-132	Feed motor bracket fab assy	1
34	12-01-050B	Top feed roller shaft	1
35	12-20-005	Rectangular key 40x10x8	1
36	12-20-004	Rectangular key 30x8x7	1

Item No	Part No	Description	Quantity
1	12-12-609	M12 x 45Lg 8.8 Socket Head Cap Screw	2
2	12-24-005	Hydraulic motor 199.6cc/rev	1
3	12-01-049	Rigid shaft coupling 25 ID	1
4	12-12-308	M5 x 20Lg Socket Head Cap Screw	4
5	12-14-010	M10 Spring Washer DIN 128	9
6	12-14-009	M10 Washer ISO 7089	9
7	12-12-509	M10 x 35Lg 8.8 Hex Head screw	2
8	12-11-013	Self aligning flange bearing 2 hole 30 ID	1
9	12-10-094	R1/8in BSPT 4mm male stud elbow	2
10	12-03-102	Feed roller 2 hole bearing shim	1
11	12-10-127 Part D	M12 spherical dish washer	1
12	12-10-127 Part C	M12 spherical washer	1
13	12-14-003	M12 Washer ISO 7089	3
14	12-13-003	M12 nyloc nut ISO 7040	3
15	12-19-080	Top feed housing fab assy	1
16	12-14-013	M8 washer ISO 7089	2
17	12-13-011	M8 nyloc nut ISO 7040	2
18	12-11-004	Plain bearing 20 ID, 26 OD, 28 flange x 12 Lg	2

Flywheel assembly 12-A-010

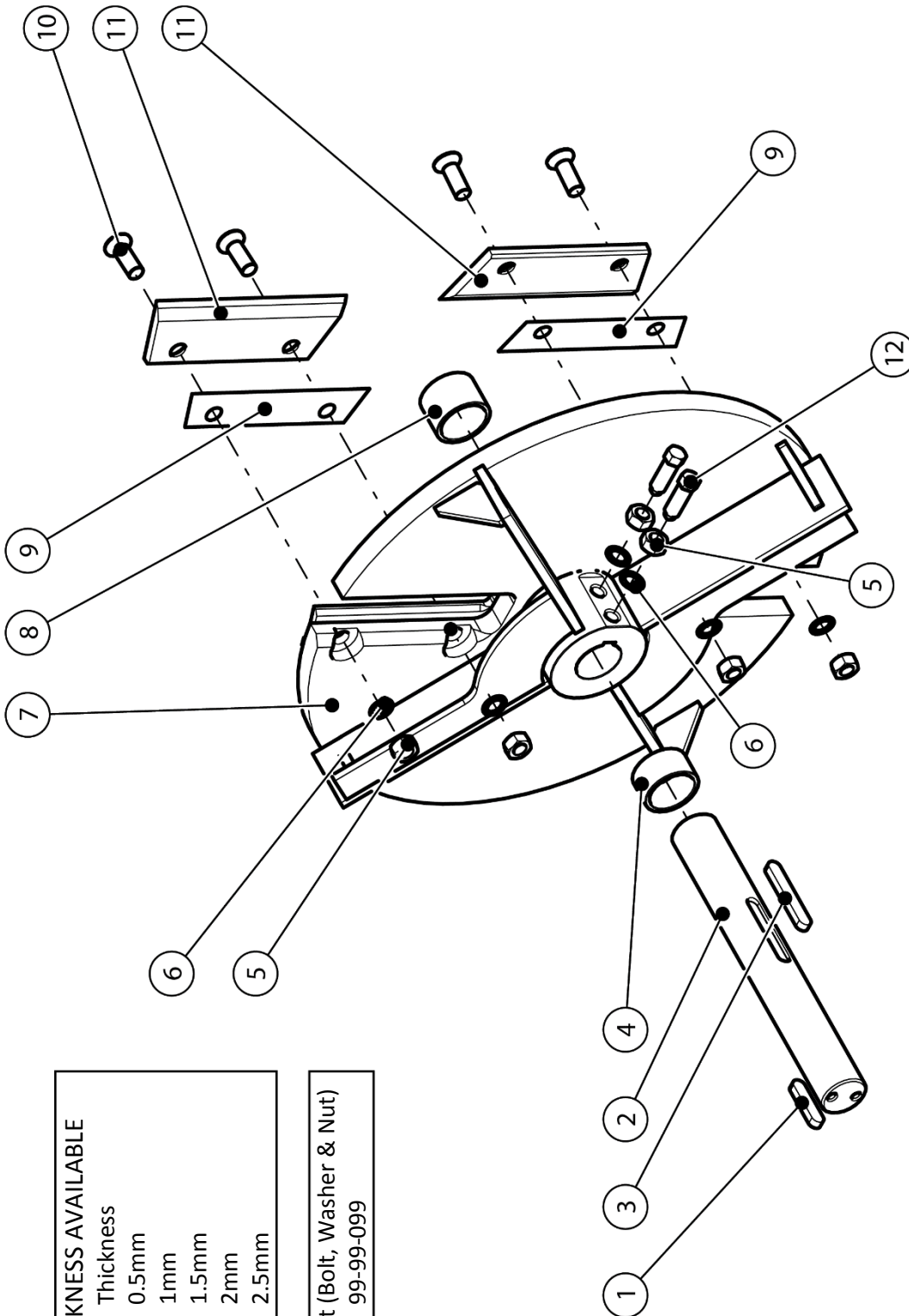

BLADE SHIM THICKNESS AVAILABLE	
Part No	Thickness
12-03-093.05	0.5mm
12-03-093.10	1mm
12-03-093.15	1.5mm
12-03-093.20	2mm
12-03-093.25	2.5mm

Note: Blade Bolt Set (Bolt, Washer & Nut)
Part No 99-99-099

Item No	Part No	Description	Quantity
1	12-20-003	Rectangular key 60x14x9	1
2	12-01-007	Flywheel shaft	1
3	12-20-002	Rectangular key 90x14x9	1
4	12-01-046	Flywheel shaft spacer	1
5	12-13-007	M16 10.9 Hex nut ISO 4032	6
6	12-14-006	M16 serrated lock washer DIN 6798-A17	6

Item No	Part No	Description	Quantity
7	12-01-042	Flywheel machined assy	1
8	12-01-012	Flywheel shaft spacer	1
9	12-03-093.05	Blade shim 0.5mm	2
10	12-12-1102	M16 x 45lg 10.9 CSK hex socket screw ISO 10642	4
11	12-01-009	Flywheel blade	2
12	12-12-1103	M16 x 50lg 8.8 Hex Head screw cone point DIN 564	2

Flywheel belt tensioner assembly 12-A-012

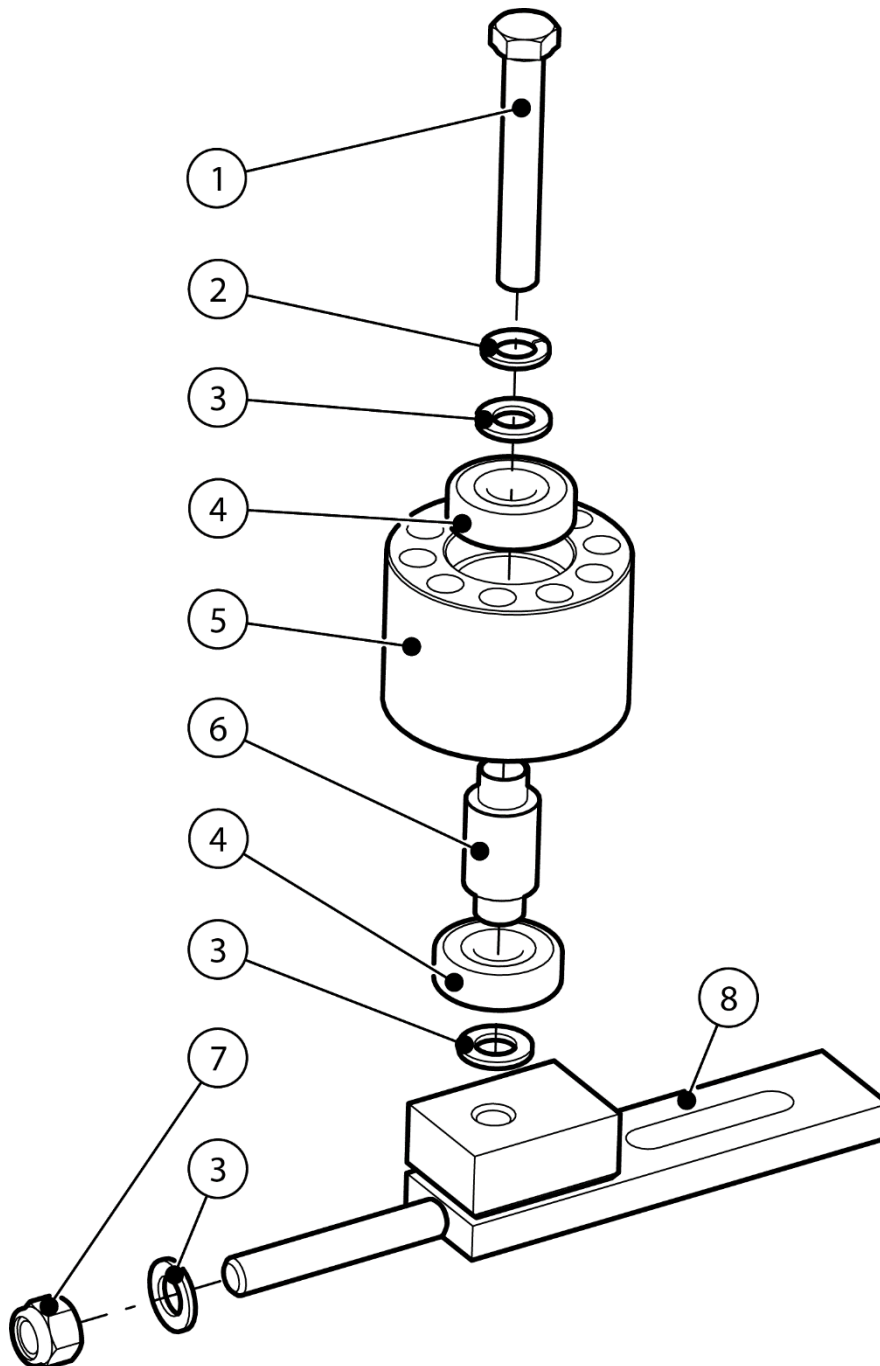

Item No	Part No	Description	Quantity
1	12-12-1104	M16 x 110Lg 8.8 Hex Head bolt	1
2	12-14-019	M16 Spring washer DIN 128	1
3	12-14-005	M16 Washer ISO 7089	3
4	12-11-011	6304 2RS Deep groove ball bearing 52 OD, 20 ID, 15 wide	2
5	12-01-036	Flat idler pulley-2x 17 V belt	1
6	12-01-024	Flat idler pulley shaft-2x 17 V belt	1
7	12-13-005	M16 nyloc nut ISO 7040	1
8	12-19-062	Tensioner slide fab assy	1

Fuel tank assembly 12-A-026

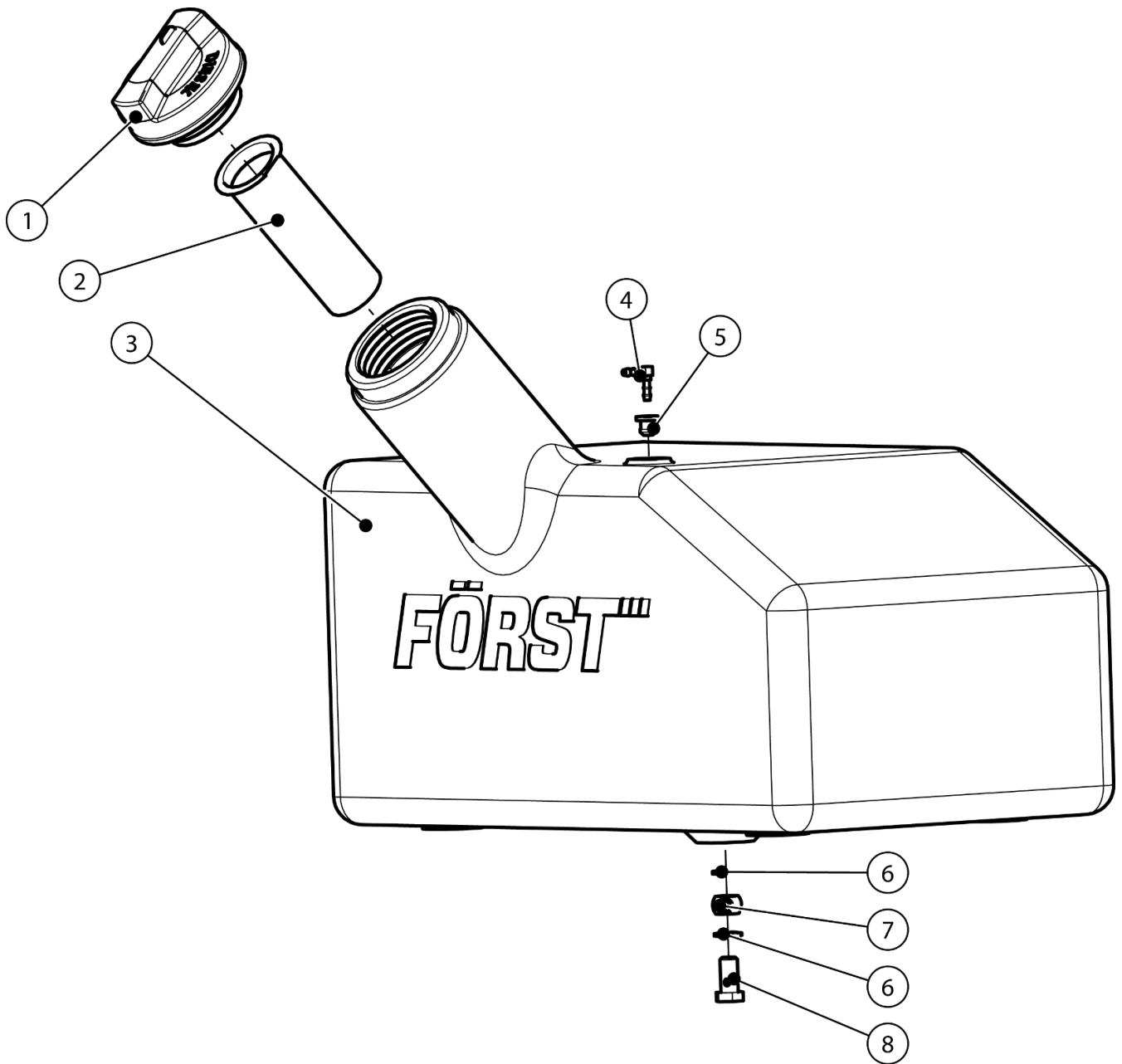

Item No	Part No	Description	Quantity
1	12-10-150	Fuel tank cap	1
1a	12-10-151	Lockable tank cap (optional)	1
2	12-10-152	Fuel tank filter	1
3	12-02-001	Fuel tank 35L moulded assy	1
4	12-10-154	Fuel tank 5mm connector	1
5	12-10-153	Fuel tank 5mm grommet	1
6	12-14-008	M12 Bonded washer (Dowty)	2
7	12-10-027	Banjo M12	1
8	12-10-026	Banjo bolt M12	1

Hydraulic pump assembly 12-A-022

Item No	Part No	Description	Quantity
1		Comes with pump	1
2		Comes with pump	1
3	12-01-045	Pump pulley 1	1
4	12-19-069	Pump mounting plate fab assy	1
5		Comes with pump	1
6	12-24-004	Hydraulic pump 11cc assy	1
7	12-14-013	M8 washer ISO 7089	4
8	12-14-014	M8 Spring washer DIN 128	4
9	12-12-408	M8 x 30 Lg 8.8 Socket Head Cap Screw	4

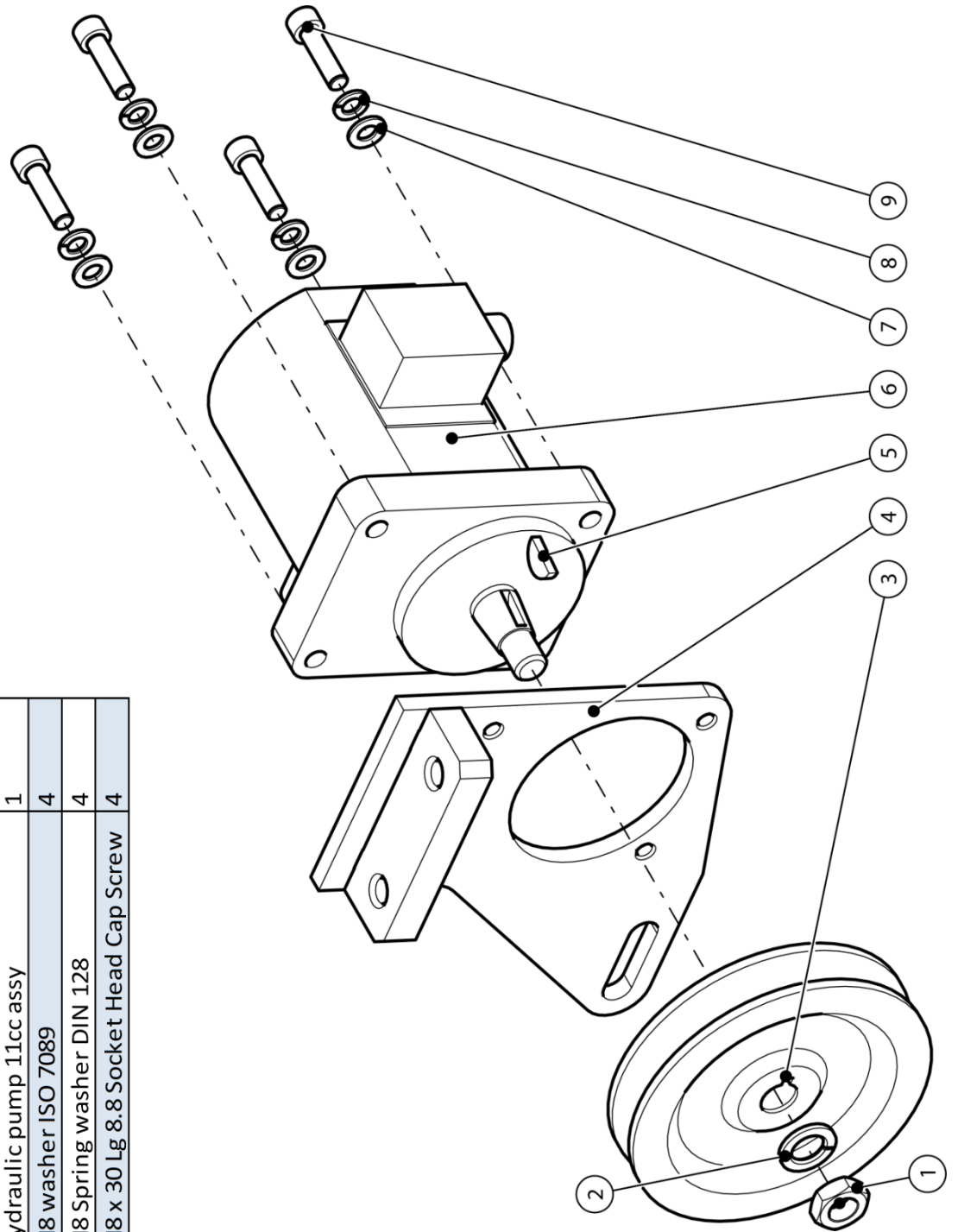

Light board assembly 12-A-024

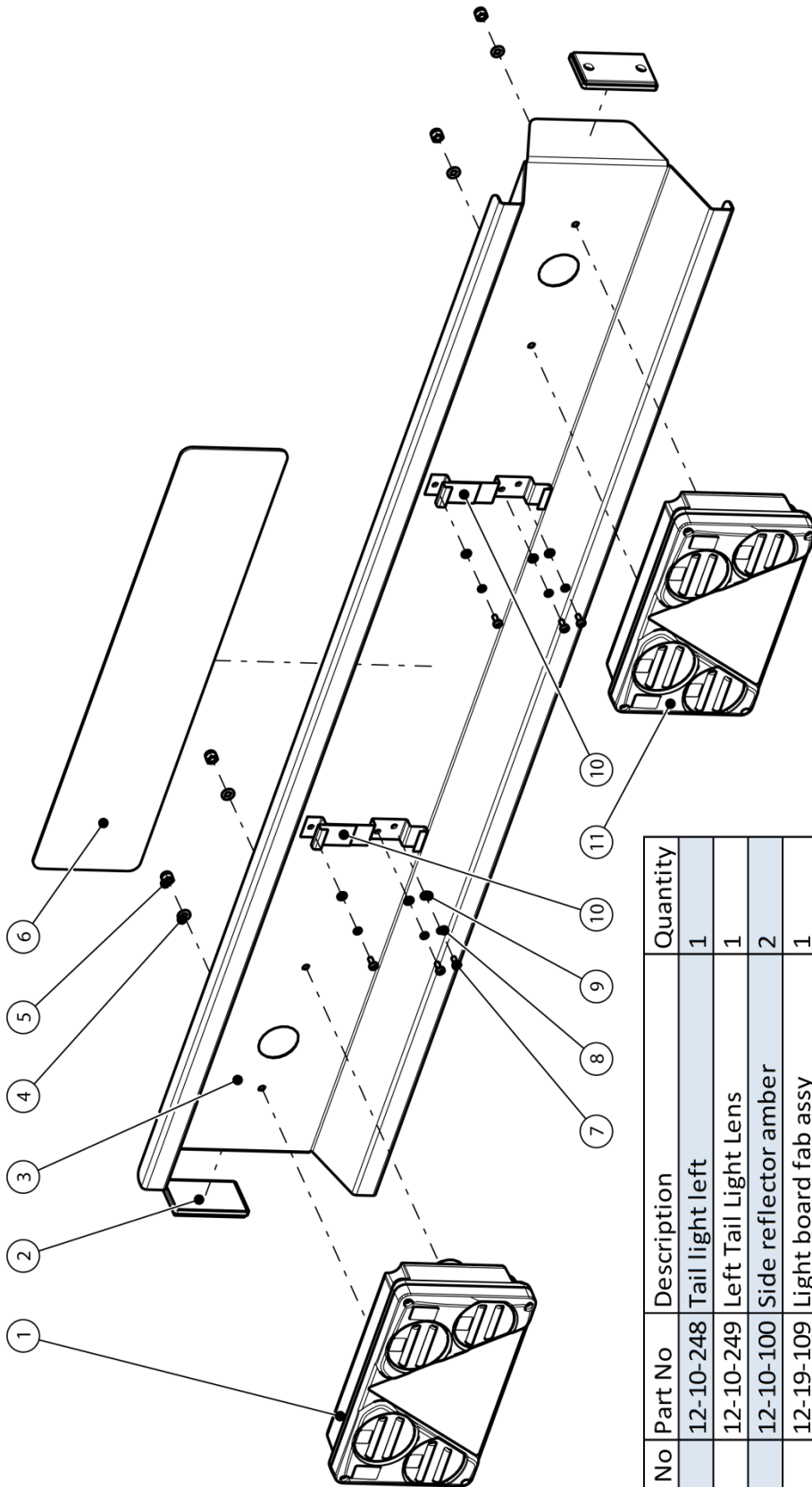

Item No	Part No	Description	Quantity
1	12-10-248	Tail light left	1
1a	12-10-249	Left Tail Light Lens	1
2	12-10-100	Side reflector amber	2
3	12-19-109	Light board fab assy	1
4	12-14-017	M6 washer ISO 7089	4
5	12-13-015	M6 nyloc nut ISO 7040	4
6		Trailer number plate	1
7	12-99-006	M4 x 10 Pan Head Pozi Screw	6
8	12-14-021	M4 Spring washer DIN 128	6
9	12-14-020	M4 washer ISO 7089	6
10	12-10-097	Number plate holder (each)	2
11	12-10-250	Tail light right	1
11a	12-10-251	Right Tail Light Lens	1
	12-10-252	LED Loom complete	1
	12-10-253	Curly cable	1

Note: Light guards available on request Part no: 12-19-130

Running gear – hitch & axle

Please refer to maintenance instruction manual supplied with the machine.

Hydraulics circuit diagram

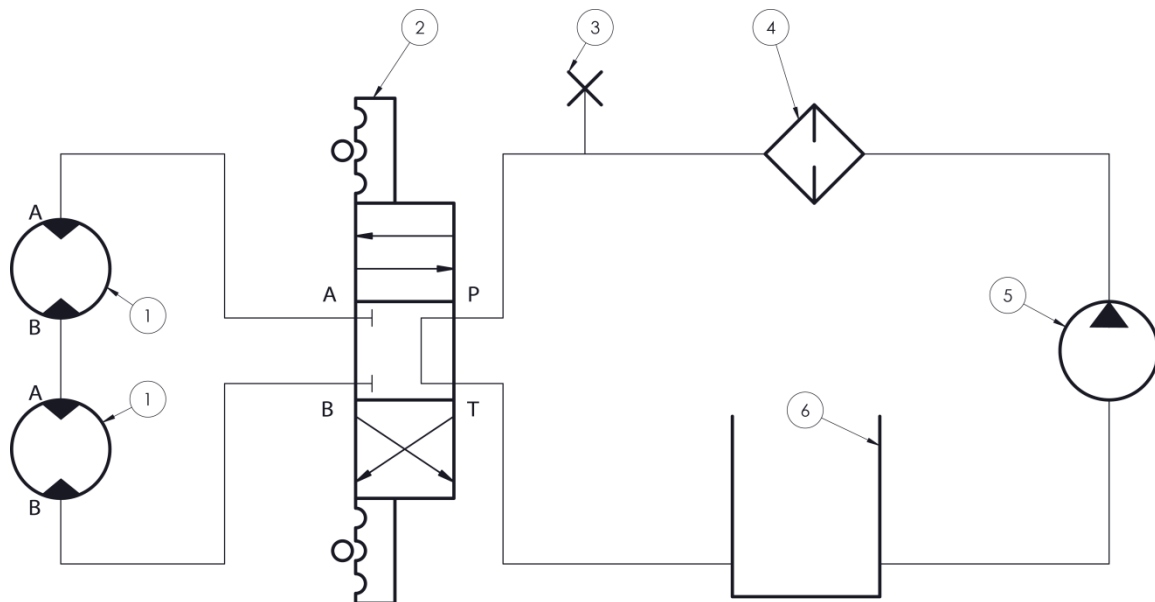

1	Motor
2	Control valve
3	Test point
4	Filter
5	Pump
6	Oil tank

Electrical circuit diagram – Mechanical & touch sensor hopper

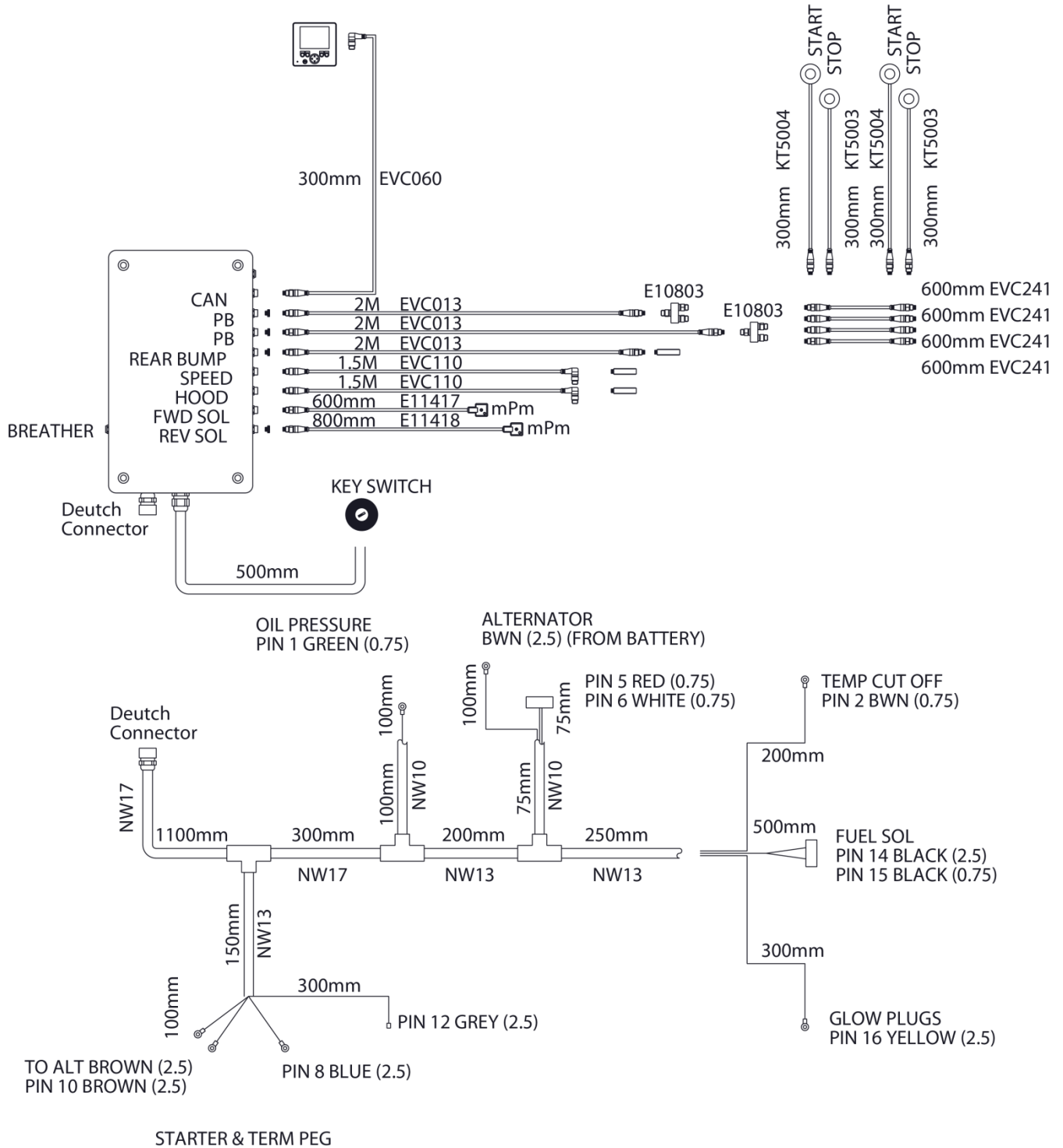

Decals

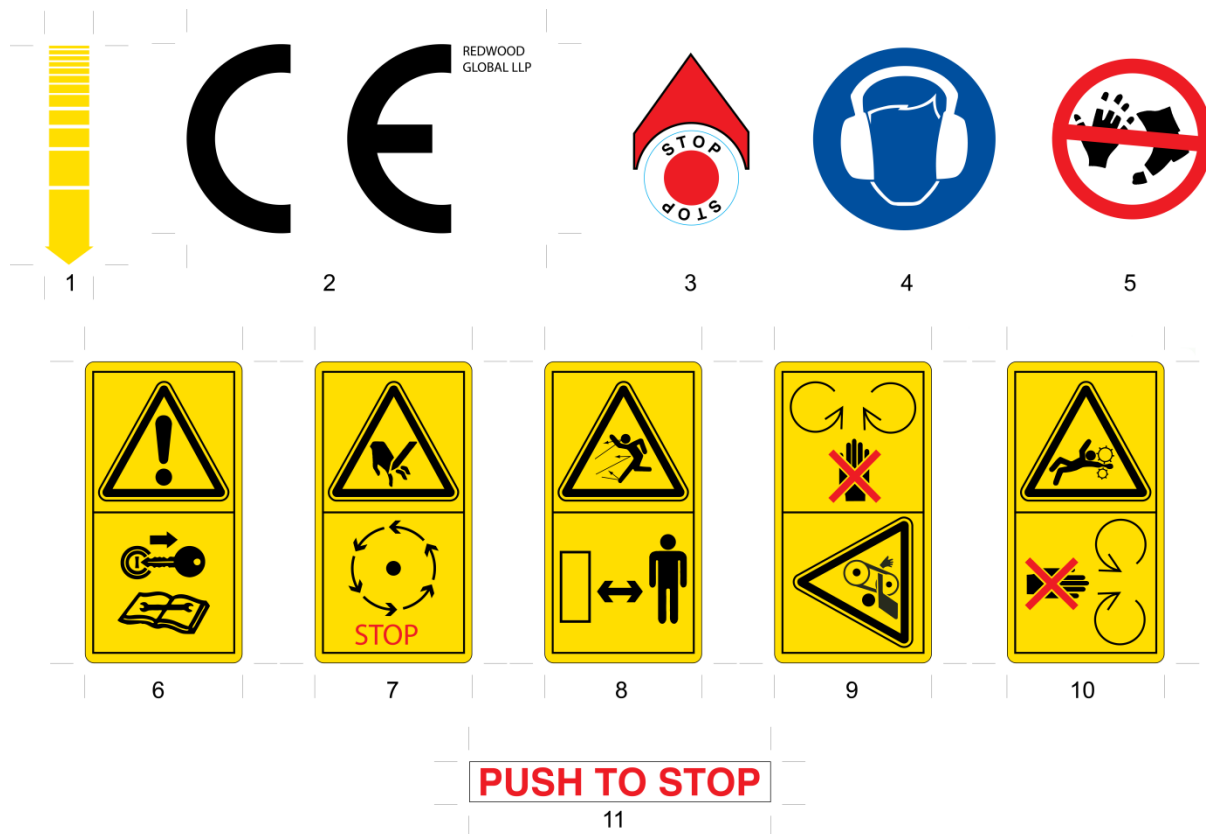

Decal meaning:

1. Throttle movement relation to engine speed.
2. CE (Conformite Europeene or European Conformity) mark. Manufacturer's declaration that the product complies with the essential requirements of the relevant European health, safety and environment protection legislation.
3. Ignition switch stop.
4. Hearing and eye protection of an appropriate specification to be worn.
5. Finger and toe amputation hazard.
6. Refer to user manual.
7. Allow machine to stop before touching.
8. Danger from flying objects.
9. Do not open or remove covers while engine is running.
10. Keep away from rotating machine parts.
11. Push to stop, trip bar operation.

These decals are placed on the machine where the hazard or information applies.

Manufacturer's Statutory Plate

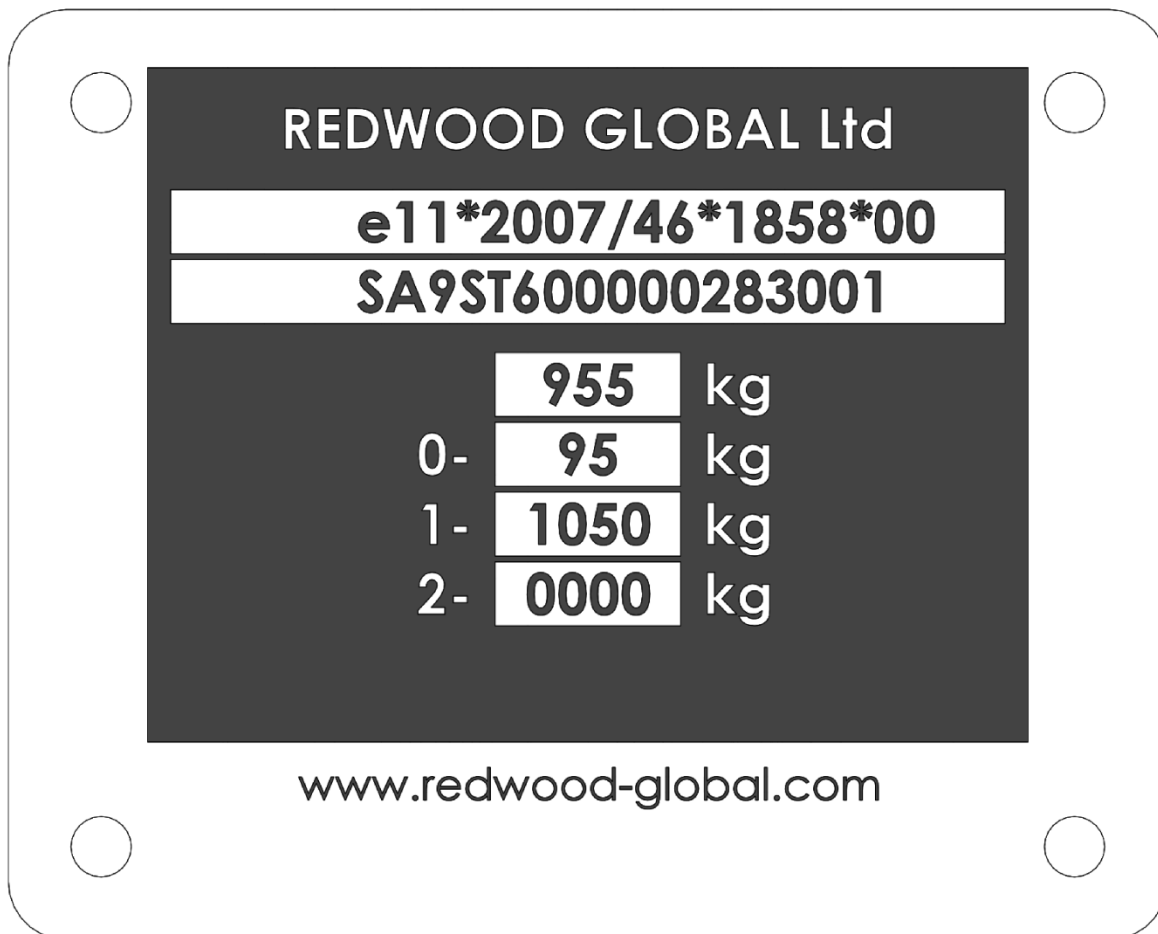

Information on the Manufacturer's Statutory Plate in line order from top to bottom is as follows:

1. Manufacturing company.
2. Vehicle type approval number and construction date.
3. 17 digit Vehicle Identification Number (VIN) construction.
4. Gross Vehicle Weight (GVW).
5. 0- Nose weight.
6. 1 - Axle mass.
7. 2 - Location.

Warranty

Warranty statement

1. Redwood Global Ltd guarantee all Forst equipment supplied by them against any defect in manufacture and assembly – this guarantee is for a period of 12 months commencing on the date of sale to the first end user.
2. The guarantee will not apply to a failure where normal use has exhausted the life of a component.
3. Engine units are covered independently by their respective manufacturer's warranties.
4. Redwood Global Ltd's liability under this guarantee is limited to repair at Redwood Global Ltd's premises or at a selected Forst dealer.
5. No liability will be accepted for consequential lost or damage of any kind.
6. The Redwood Global Ltd guarantee is restricted to the first Redwood Global Ltd user only and is not transferable except when authorized by Redwood Global Ltd.
7. The owner is responsible to make sure the machine is operated at all times in accordance with the user manual.
8. The Redwood Global Ltd guarantee will be invalidated if any of the following points apply:
 - Failure to use genuine Forst parts
 - Failure to perform routine servicing and maintenance
 - Failed parts or assembly have been interfered with
 - Machine has been modified without written approval from Redwood Global Ltd
 - Machine has been used to performed tasks contrary to those stated in the Redwood Global Ltd User Manual
 - Exclusions to the above warranty terms are – fair wear and tear on fuses and bulbs, tyres and brakes, lubrications and filters, blades and anvils, feed rollers and paintwork.
 - Where an extended warranty has been given this will be stated on the original machine invoice and will be subject to further conditions as stated in our supplementary warranty terms

Warranty claims

To obtain warranty service please contact Redwood Global Ltd for the nearest approved Forst Dealer. Your nearest dealer can be obtained from Redwood Global Ltd at the address on the front of the User Manual. In the event of a failure Redwood Global Ltd must be notified within 7 working days.

CE Certificate

FÖRST™

**CERTIFICATE & DECLARATION OF CONFORMITY
FOR CE MARKING**

Company contact details:

Redwood Global Ltd,
Unit 86, Livingstone Road, Walworth Business Park, Andover,
Hampshire. SP10 5NS. United Kingdom

Redwood Global Ltd declares that their:

Wood Chippers listed as the following models
ST6 Towed & TR6 on Tracks
ST8 Towed & TR8 on Tracks

are classified within the following EU Directives:

Machinery Directive 2006/42/EC
Electromagnetic Compatibility Directive 2004/108/EC

and further conform with the following EU Harmonized Standards:

EN13525:2005 + A2:2009
EN 982:1996+A1:2008
EN ISO 12100:2010
EN ISO 14982:2009

Dated:

Position of signatory: Managing Partner

Name of Signatory: Raymond Gardner

Signed below:

.....

on behalf of Redwood Global Ltd